



PARTS CATALOGUE



DPBMC



PGD



MDNM8

MTN155 (BHM2) MALAYSIA

MTN155
PARTS CATALOGUE
©2021 by Yamaha Motor Co., Ltd.
1st edition, April 2021
All rights reserved.
Any reprinting or unauthorized use
without the written permission of
Yamaha Motor Co., Ltd.
is expressly prohibited.
Printed in Japan.

FOREWORD

This Parts Catalogue is related to the parts for the model(s) on the cover page. When you are ordering replacement parts, please refer to this Parts Catalogue and quote both part numbers and part names correctly.

1. Modifications or additions which have been made after the issue of the Parts Catalogue will be announced in the Parts News.
It is advisable that you make the necessary corrections to the Parts Catalogue according to the Parts News.

2. Abbreviations

The following abbreviations are used in this Parts Catalogue.

“UR” Use specified parts number.

“UN” Use as many as needed.

“AP” Alternate Parts

“LM” Locally Made (Parts need to be ordered locally)

“F#” Frame No. (Applicable machine No.)

“O/S” Over Size

3. The number of components for assembly

- Parts, which are to be supplied in an assembly, are listed with a dot (.) in front of the part name as shown below.
- The numeral appearing to the right of each component part indicates the quantity of parts for each assembly unit.

PART NO.	DESCRIPTION	Q'TY	REMARKS
2F5-83310-60	FRONT FLASHER LIGHT ASSY	2	
115-83311-60	.BULB (6V-18W)	1	

4. Applicable colours of graphics are represented in the “REMARKS” as shown below.

PART NO.	DESCRIPTION	Q'TY	REMARKS
2N4-24110-00-X5	FUEL TANK COMP.	2	MXR
3J1-24240-10	.GRAPHIC, FUEL TANK	1	FOR MXR

5. Note that the illustrations for reference in finding parts numbers are not to be used for assembling. When assembling, please use the applicable service manual.

6. The asterisk (*) before a reference number indicates modified items after the first edition.

FOREWORD

7. Applicable Serial No.

Frame Serial No.

Engine Serial No.

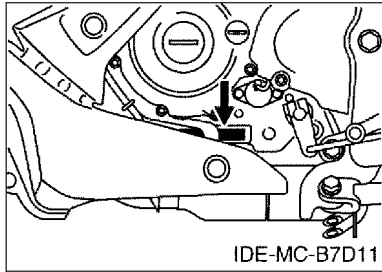
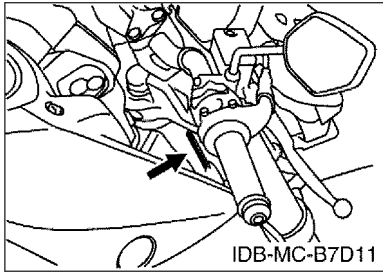

8. Applicable Colour Code (The (*) mark shows Model colour.)

Abbreviation	Colour Name	Colour Code
DPBM15	DEEP PURPLISH BLUE METALLIC 15	1329
DPBMC(*)	DEEP PURPLISH BLUE METALLIC C	0564
LGB	LOW GLOSS BLACK	0098
MBNM3	MAT BLUISH GRAY METALLIC 3	1758
MDNM8(*)	MAT DARK GRAY METALLIC 8	1654
PGD(*)	PASTEL DARK GRAY	003E
SM12	BLACK METALLIC 12	1723
VYRS6	VIVID YELLOWISH RED SOLID 6	1699

9. Applicable Starting Serial No.

Frame Serial No.

Serial No.	Name Of Q'ty Column	Model Code

Engine Serial No.

Serial No.	Name Of Q'ty Column	Model Code

CONTENTS

ENGINE

CYLINDER HEAD.....	1
CRANKSHAFT & PISTON.....	2
VALVE.....	4
CAMSHAFT & CHAIN.....	5
WATER PUMP.....	6
RADIATOR & HOSE.....	7
OIL PUMP.....	8
INTAKE.....	9
EXHAUST.....	11
CRANKCASE.....	12
CRANKCASE COVER 1.....	13
STARTER CLUTCH.....	14
CLUTCH.....	15
TRANSMISSION.....	17
SHIFT CAM & FORK.....	19
SHIFT SHAFT.....	20

CHASSIS

FRAME.....	21
FENDER.....	22
SIDE COVER.....	24
REAR ARM & SUSPENSION.....	26
STEERING.....	27
FRONT FORK.....	28
FUEL TANK.....	30
FUEL TANK 2.....	31
SEAT.....	34
FRONT WHEEL.....	35
FRONT BRAKE CALIPER.....	36
REAR WHEEL.....	37
REAR BRAKE CALIPER.....	38
STEERING HANDLE & CABLE.....	39
FRONT MASTER CYLINDER.....	40
STAND & FOOTREST.....	41
REAR MASTER CYLINDER.....	43
LEG SHIELD.....	44
GENERATOR.....	46
STARTING MOTOR.....	47
FLASHER LIGHT.....	48

METER.....	49
HEADLIGHT.....	50
TAILLIGHT.....	51
HANDLE SWITCH & LEVER.....	52
ELECTRICAL 1.....	53
ELECTRICAL 2.....	54

INDEX

NUMERICAL INDEX.....	56
----------------------	----

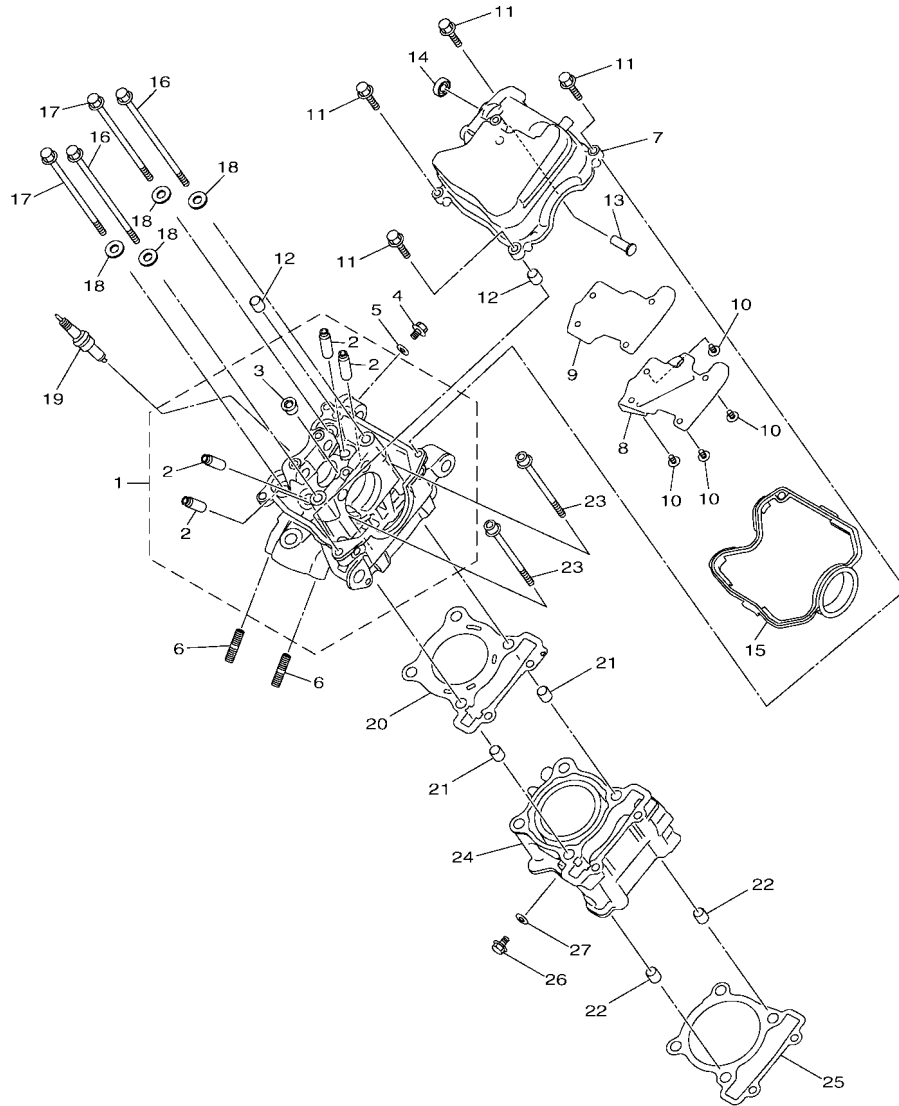
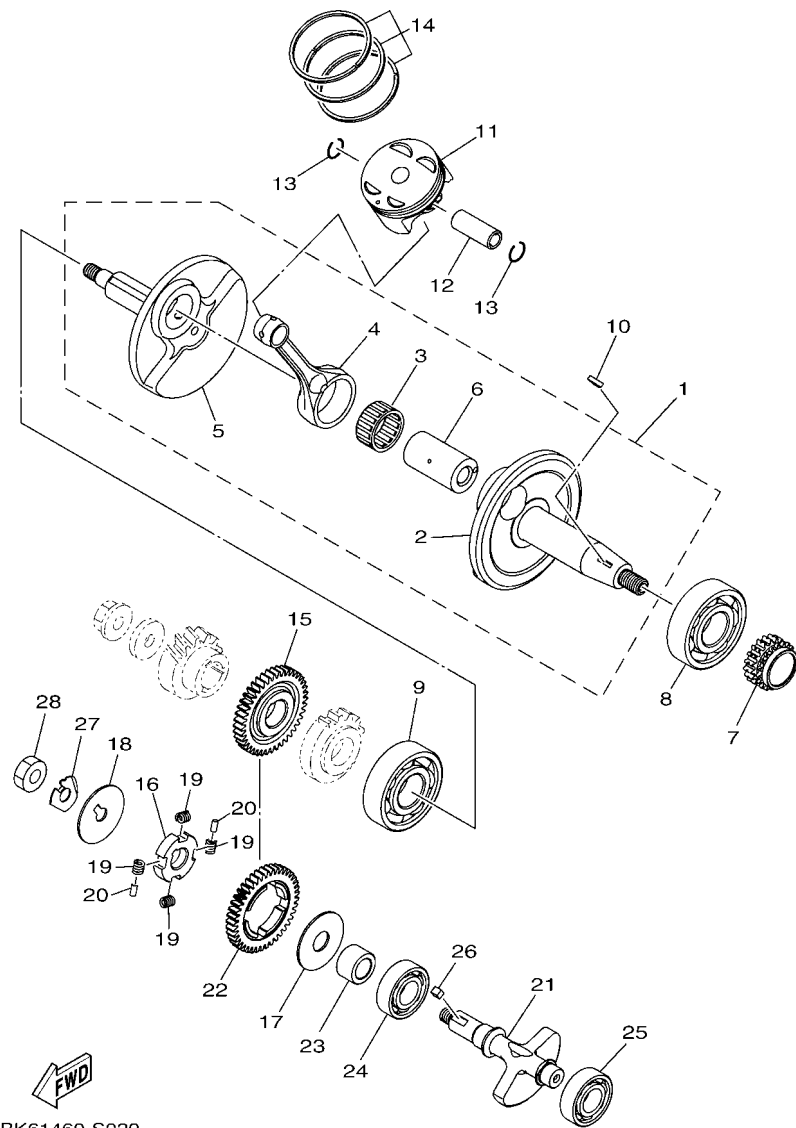

FIG. 1 CYLINDER HEAD

REF. NO.	PART NO.	DESCRIPTION	BHM2	REMARKS
1	BK6-E1102-00	CYLINDER HEAD ASSY	1	
2	2DP-E1133-10	.GUIDE, VALVE 1	4	
3	90340-12813	.PLUG, STRAIGHT SCREW	1	
4	95E32-06010	BOLT, FLANGE DEEP RECESS	1	
5	90430-06803	GASKET	1	
6	95612-08618	BOLT, STUD	2	
7	BK6-E1191-00	COVER, CYLINDER HEAD 1	1	
8	BK6-E1165-00	PLATE, BREATHER	1	
9	BK6-E1169-00	GASKET, BREATHER COVER	1	
10	90149-05801	SCREW	4	
11	95E32-06030	BOLT, FLANGE DEEP RECESS	4	
12	99530-08012	PIN, DOWEL	2	
13	BK6-E132G-00	ROD 1	1	
14	93102-08800	OIL SEAL	1	
15	B3F-E1193-00	GASKET, HEAD COVER 1	1	
16	BK6-E1361-00	BOLT, CYLINDER HOLDING 1	2	
17	BK6-E1362-00	BOLT, CYLINDER HOLDING 2	2	
18	90201-08859	WASHER, PLATE	4	
19	94700-00439	PLUG, SPARK (NGK MR8E-9)	1	
20	2DP-E1181-00	GASKET, CYLINDER HEAD 1	1	
21	99530-10114	PIN, DOWEL	2	
22	99530-10114	PIN, DOWEL	2	
23	90110-06378	BOLT, HEXAGON SOCKET HEAD	2	
24	2DP-E1311-10	CYLINDER 1	1	
25	BK6-E1351-00	GASKET, CYLINDER	1	
26	95E32-06010	BOLT, FLANGE DEEP RECESS	1	
27	90430-06803	GASKET	1	



B7D1431-U010



BK61460-S020

FIG. 2 CRANKSHAFT & PISTON

REF. NO.	PART NO.	DESCRIPTION	BHM2				REMARKS
1	BK6-E1400-00	CRANKSHAFT ASSY	1				
2	BK6-E1412-00	.CRANK 1	1				
3	93310-526YT	.BEARING	1				
4	BK6-E1651-00	.ROD, CONNECTING	1				
5	BK6-E1422-00	.CRANK 2	1				
6	BK6-E1681-00	.PIN, CRANK 1	1				
7	BK7-E1549-00	SPROCKET, CAM CHAIN	1				
8	93306-305X7	BEARING	1				
9	93306-305XV	BEARING	1				
10	90280-03017	KEY, WOODRUFF	1				
11	BK6-E1631-00	PISTON (STD)	1				
12	2DP-E1633-00	PIN, PISTON	1				
13	93450-16115	CIRCLIP	2				
14	BK6-E1603-00	PISTON RING SET (STD)	1				
15	BK6-E1536-00	GEAR, DRIVE	1				
16	21C-E1496-20	BOSS, BUFFER	1				
17	90201-15821	WASHER, PLATE	1				
18	90214-10800	WASHER, CLAW	1				
19	90501-16800	SPRING, COMPRESSION	4				
20	93604-08071	PIN, DOWEL	2				
21	BK7-E1454-00	WEIGHT 1	1				
22	BK6-E1531-10	GEAR, BALANCE WEIGHT	1				
23	90387-15810	COLLAR	1				
24	93306-203XK	BEARING	1				
25	93306-203XK	BEARING	1				
26	90282-05031	KEY, STRAIGHT	1				
27	90215-10803	WASHER, LOCK	1				

FIG. 3 VALVE

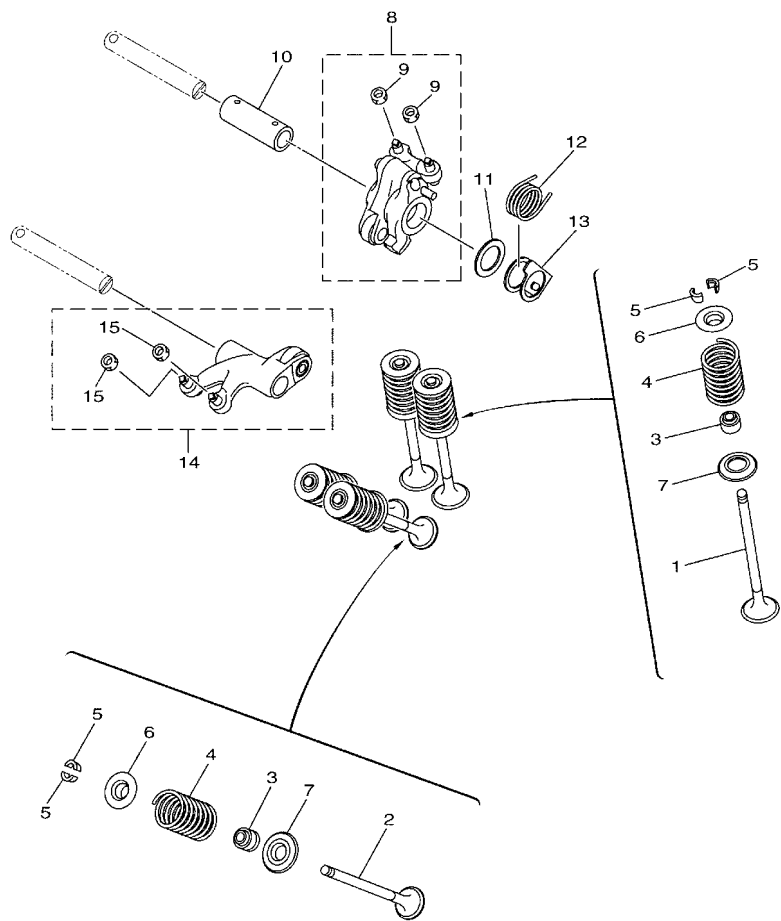

REF. NO.	PART NO.	DESCRIPTION	BHM2				REMARKS
1	BK6-E2111-00	VALVE, INTAKE	2				
2	BK6-E2121-00	VALVE, EXHAUST	2				
3	54P-E2119-00	SEAL, VALVE STEM	4				
4	B63-E2113-00	SPRING, VALVE INNER	4				
5	5TL-E2118-00	LOCK, VALVE SPRING RETAINER	8				
6	2DP-E2117-00	RETAINER, VALVE SPRING	4				
7	50C-E2126-00	SEAT, VALVE SPRING 2	4				
8	BK6-E2150-00	VALVE ROCKER ARM ASSY	1				
9	90170-05803	.NUT	2				
10	BK6-E2166-00	SHAFT, ROCKER 3	1				
11	BK6-E1557-00	WASHER 1	1				
12	BK6-E2226-00	SPRING, COIL	1				
13	BK7-E2279-00	PLATE	1				
14	BK6-E2160-00	VALVE ROCKER ARM ASSY 2	1				
15	90170-05803	.NUT	2				



B7D1431-U030

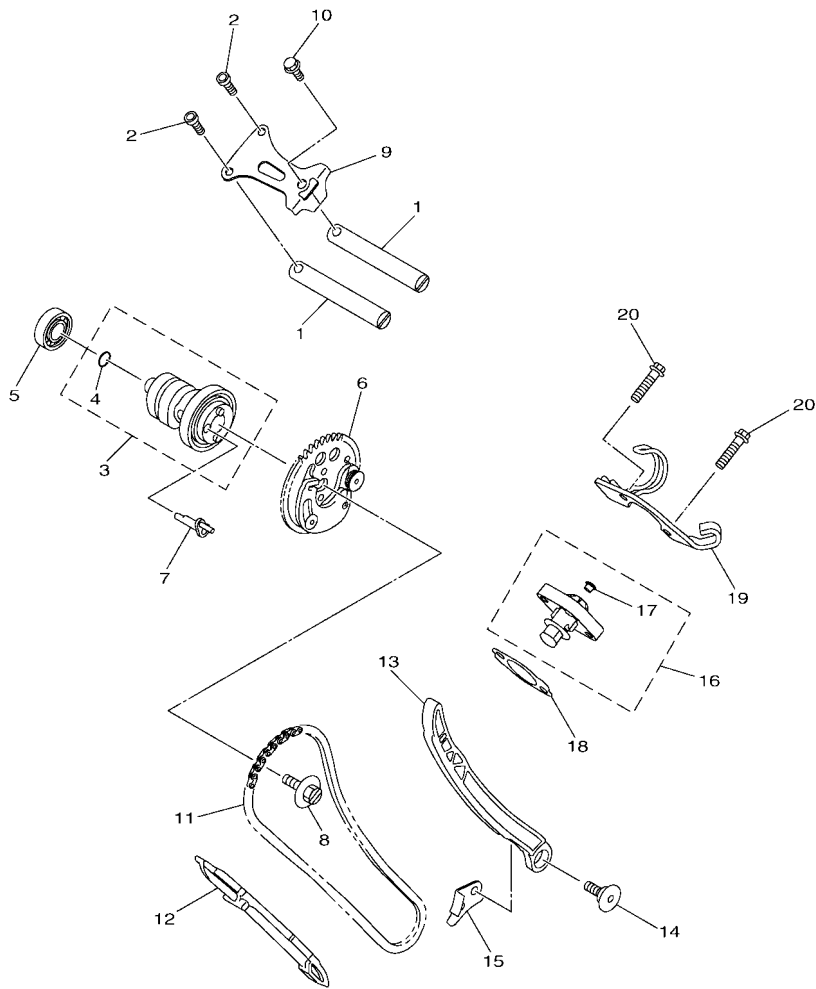

FIG. 4 CAMSHAFT & CHAIN

REF. NO.	PART NO.	DESCRIPTION	BHM2					REMARKS
1	21C-E2156-00	SHAFT, ROCKER 2	2					
2	91312-05016	BOLT, HEXAGON SOCKET HEAD	2					
3	BK6-E2170-01	CAMSHAFT ASSY 1	1					
4	93210-09806	.O-RING	1					
5	93306-001YJ	BEARING	1					
6	BK6-E2280-01	DECOMPRESSION ASSY	1					
7	BK6-E2288-00	CAM, DECOMPRESSION	1					
8	5YP-E2157-01	BOLT	1					
9	B63-E111F-00	PLATE	1					
10	95E32-06014	BOLT, FLANGE DEEP RECESS	1					
11	94568-J9096	CHAIN	1					
12	B65-E2231-00	GUIDE, STOPPER 1	1					
13	BK6-E2241-00	GUIDE, STOPPER 2	1					
14	54P-E2228-00	BOLT	1					
15	BK6-E2256-00	COVER, CHAIN	1					
16	2PV-E2210-01	TENSIONER ASSY, CAM CHAIN	1					
17	5MX-E2222-00	.PLUG	1					
18	BK6-E2213-00	GASKET, TENSIONER CASE	1					
19	BK6-E5441-00	HOLDER, CLUTCH CABLE	1					
20	95E32-06025	BOLT, FLANGE DEEP RECESS	2					



B7D1431-U040

FIG. 5 WATER PUMP

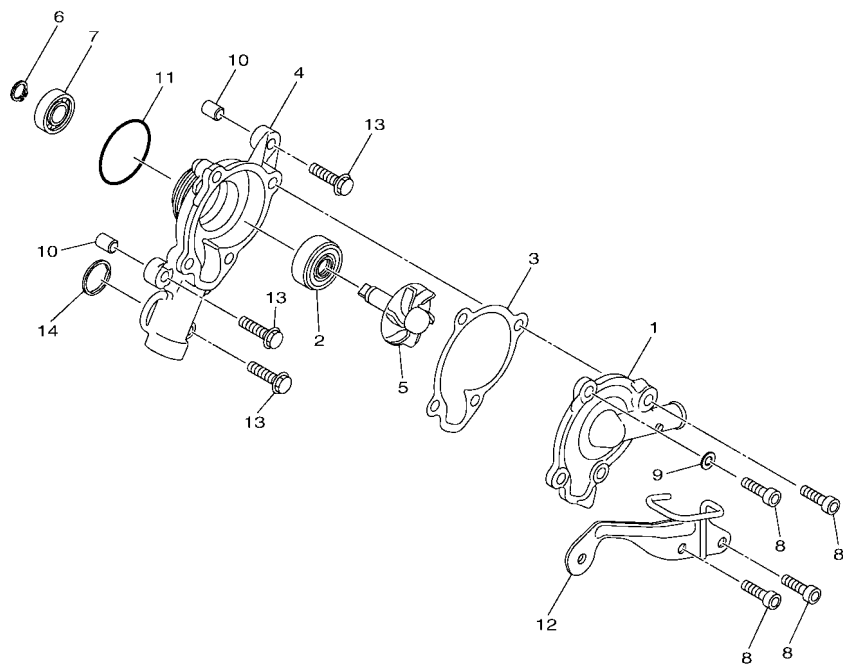

REF. NO.	PART NO.	DESCRIPTION	BHM2				REMARKS
1	BK7-E2422-00	COVER, HOUSING	1				
2	93103-10801	OIL SEAL	1				
3	2DP-E2428-00	GASKET, HOUSING COVER 2	1				
4	BK7-E1185-00	COVER, CYLINDER HEAD SIDE 3	1				
5	BK7-E2450-00	IMPELLER SHAFT ASSY	1				
6	BK7-E2842-00	CIRCLIP	1				
7	93306-000Y3	BEARING	1				
8	BK7-E2615-00	BOLT	4				
9	BK7-E2435-00	GASKET	1				
10	BK7-E3516-00	PIN, DOWEL	2				
11	93210-39803	O-RING	1				
12	BK7-E2443-00	STAY	1				
13	95E32-06025	BOLT, FLANGE DEEP RECESS	3				
14	93210-19809	O-RING	1				



B7D1431-U050

FIG. 6 RADIATOR & HOSE

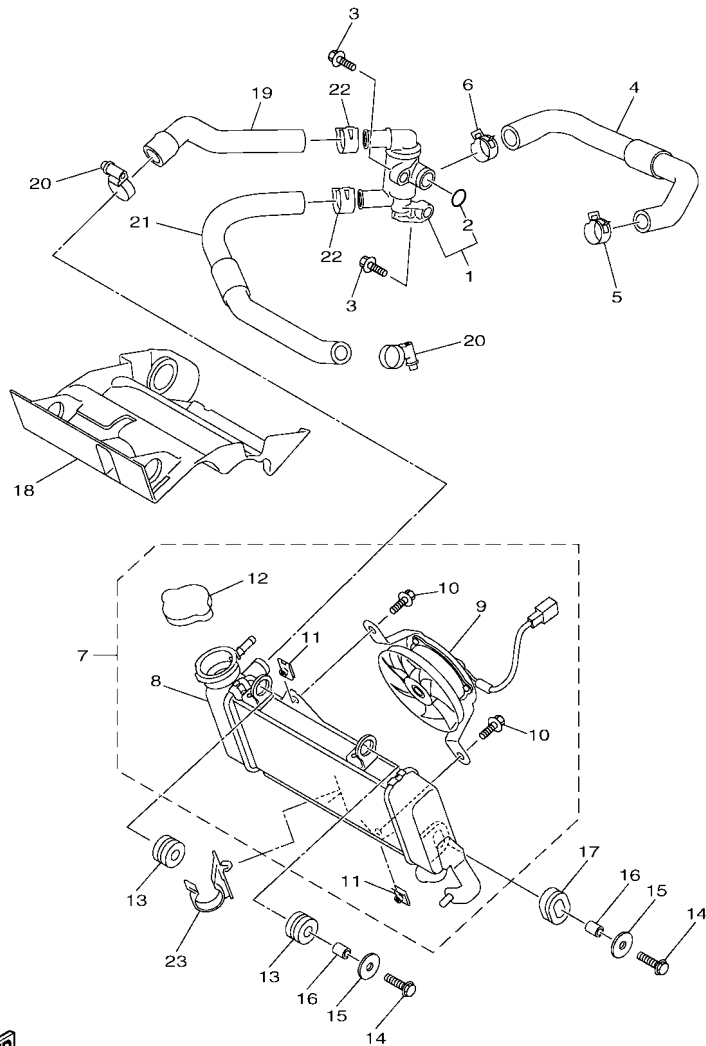

REF. NO.	PART NO.	DESCRIPTION	BHM2				REMARKS
1	BK6-E2410-00	THERMOSTAT ASSY	1				
2	52S-12439-00	.O-RING	1				
3	95E32-06020	BOLT, FLANGE DEEP RECESS	2				
4	BK6-E2483-00	PIPE 3	1				
5	90467-19803	CLIP	1				
6	90467-20806	CLIP	1				
7	BK6-E2460-00	RADIATOR ASSY	1				
8	BK6-E2461-00	.RADIATOR COMP	1				
9	BK6-E2405-00	.BLOWER ASSY	1				
10	5YP-E2675-00	.BOLT, BLOWER HOLDING	2				
11	5YP-E2671-00	.NUT 1	2				
12	5P0-E2590-00	.CONDUCTION ASSY	1				
13	90480-15363	GROMMET	2				
14	95D32-06025	BOLT, FLANGE DEEP RECESS	2				
15	90201-06880	WASHER, PLATE	2				
16	90387-064W3	COLLAR	2				
17	90480-01803	GROMMET	1				
18	BK7-E2467-00	COVER, RADIATOR	1				
19	BK6-E2481-00	PIPE 1	1				
20	90450-27806	HOSE CLAMP ASSY	2				
21	BK6-E2482-00	PIPE 2	1				
22	90467-20805	CLIP	2				
23	3C1-F1338-00	CLAMP	1				



BFL1200-V060

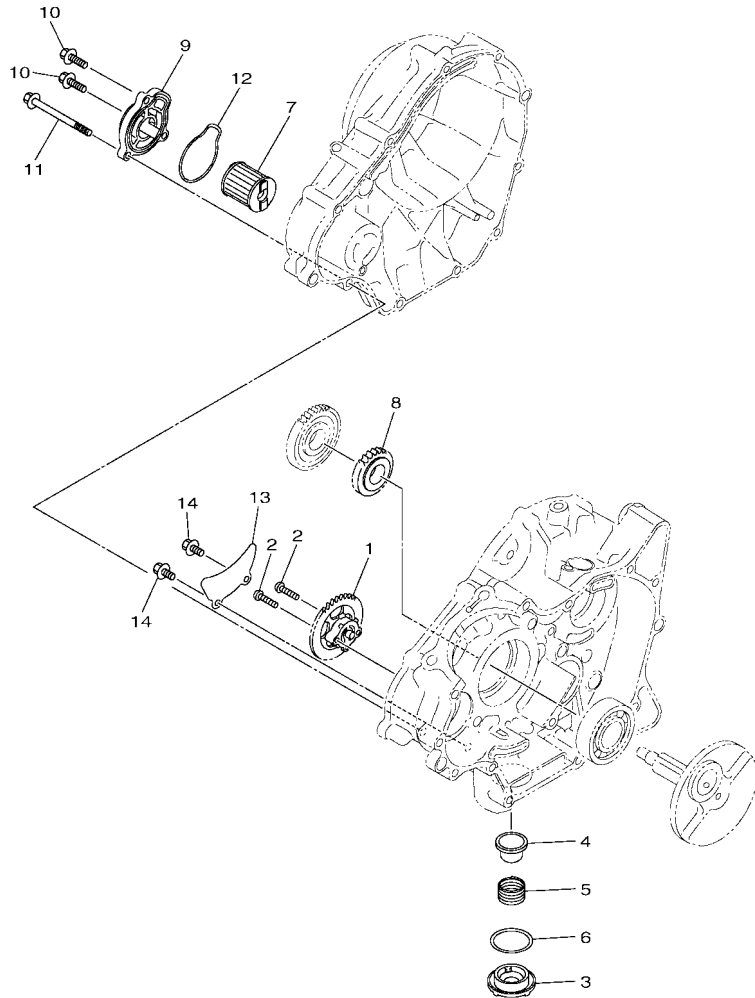
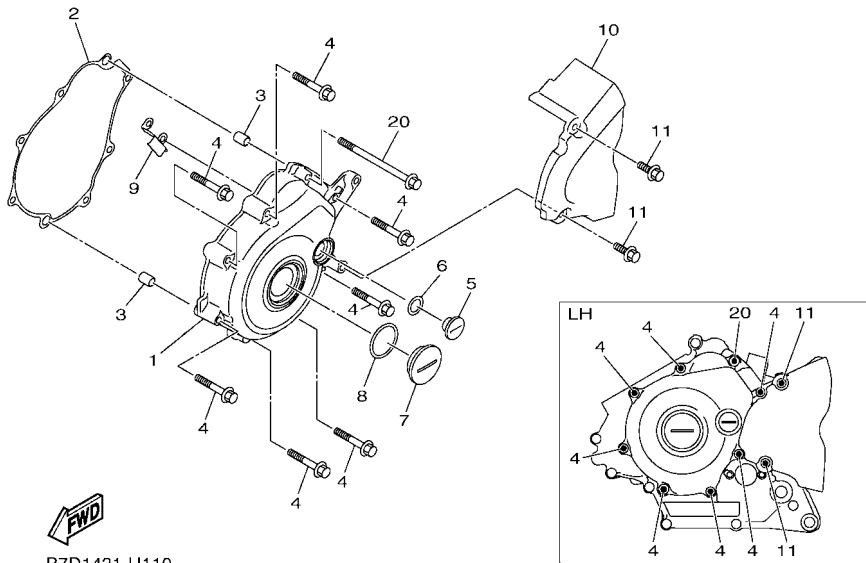
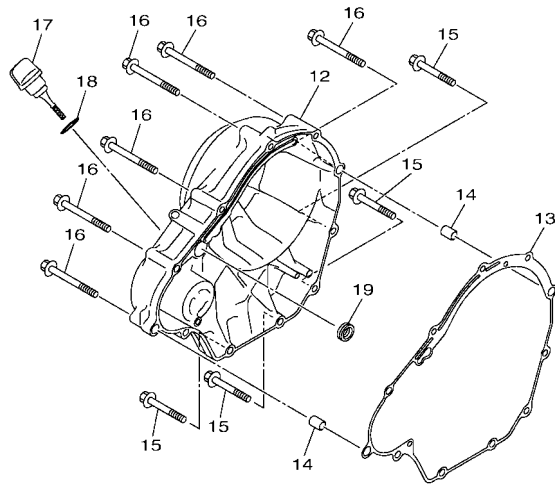
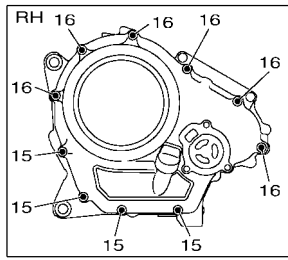

FIG. 7 OIL PUMP

REF. NO.	PART NO.	DESCRIPTION	BHM2				REMARKS
1	BK6-E3300-00	OIL PUMP ASSY	1				
2	90111-05808	BOLT,HEX. SOCKET BUTTON	2				
3	1S7-E5351-00	PLUG, DRAIN	1				
4	38B-E3411-00	STRAINER, OIL	1				
5	90501-18576	SPRING, COMPRESSION	1				
6	93210-34802	O-RING	1				
7	38B-E3440-01	ELEMENT ASSY, OIL CLEANER	1				
8	2PV-E3324-00	GEAR, PUMP DRIVE	1				
9	2PK-E3447-00	COVER, OIL ELEMENT	1				
10	95E32-06020	BOLT, FLANGE DEEP RECESS	2				
11	95E32-06080	BOLT, FLANGE DEEP RECESS	1				
12	93210-54805	O-RING	1				
13	3C1-E3327-00	COVER, PUMP GEAR	1				
14	95E32-06012	BOLT, FLANGE DEEP RECESS	2				



B7D1431-U070



B7D1431-U110

FIG. 11 CRANKCASE COVER 1

REF. NO.	PART NO.	DESCRIPTION	BHM2				REMARKS
1	BK6-E5411-00	COVER, CRANKCASE 1	1				
2	BK6-E5451-00	GASKET, CRANKCASE COVER 1	1				
3	99530-10114	PIN, DOWEL	2				
4	95022-06040	BOLT, FLANGE	7				
5	90340-14824	PLUG, STRAIGHT SCREW	1				
6	93210-148F8	O-RING	1				
7	90340-32823	PLUG, STRAIGHT SCREW	1				
8	93210-32816	O-RING	1				
9	2PV-E5113-00	PLATE	1				
10	BK6-E5418-00	COVER, CHAIN CASE	1				
11	95022-06016	BOLT, FLANGE	2				
12	BK6-E5421-00	COVER, CRANKCASE 2	1				
13	BK6-E5461-00	GASKET, CRANKCASE COVER 2	1				
14	99530-10114	PIN, DOWEL	2				
15	95022-06040	BOLT, FLANGE	4				
16	95022-06050	BOLT, FLANGE	6				
17	BK7-E5362-00	PLUG, OIL LEVEL	1				
18	93210-19809	O-RING	1				
19	93101-10843	OIL SEAL	1				
20	95022-06090	BOLT, FLANGE	1				

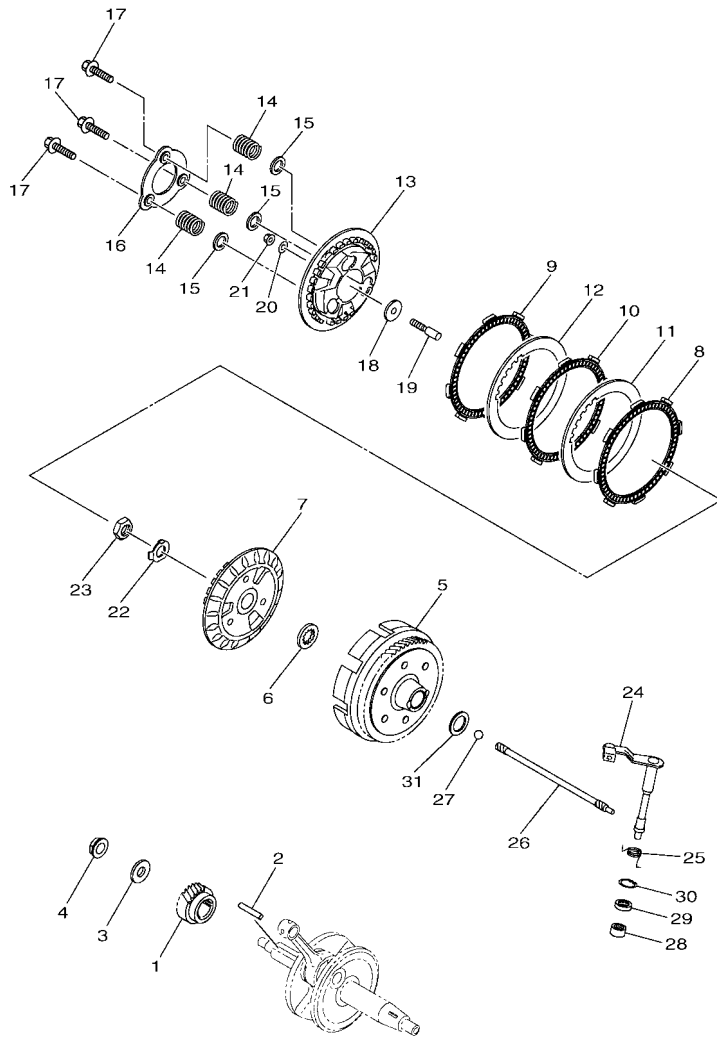
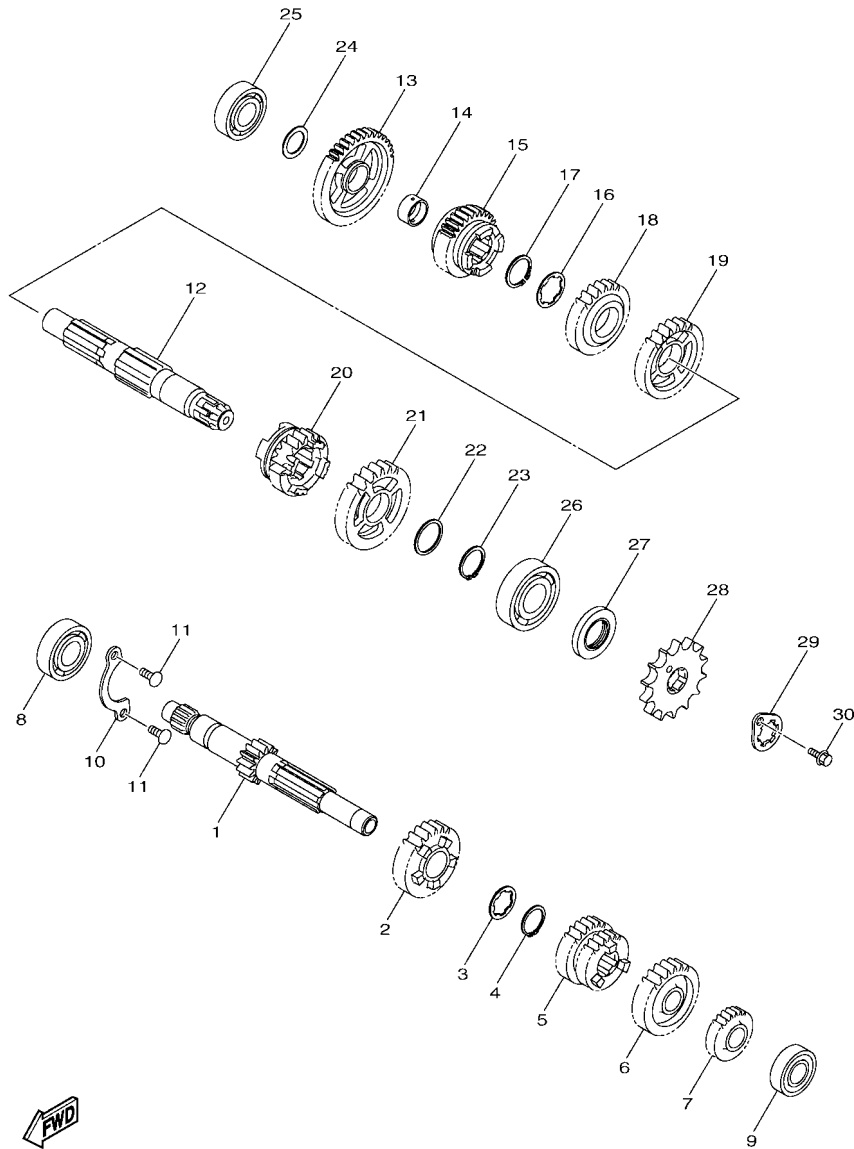

FIG. 13 CLUTCH

REF. NO.	PART NO.	DESCRIPTION	BHM2				REMARKS
1	3C1-E6111-00	GEAR, PRIMARY DRIVE	1				
2	38B-E6193-00	KEY, FEATHER	1				
3	90201-12019	WASHER, PLATE	1				
4	90179-12808	NUT	1				
5	BK6-E6150-00	PRIMARY DRIVEN GEAR COMP.	1				
6	2ND-E6154-00	PLATE, THRUST 1	1				
7	BK6-E6371-00	BOSS, CLUTCH	1				
8	2ND-E6321-00	PLATE, FRICTION	1				
9	BK6-E6331-00	PLATE, FRICTION 2	1				
10	BK6-E6321-00	PLATE, FRICTION	1				
11	BK6-E6325-00	PLATE, CLUTCH 2	1				
12	BK6-E6324-00	PLATE, CLUTCH 1	1				
13	BK6-E6351-00	PLATE, PRESSURE 1	1				
14	BK6-E6333-00	SPRING, CLUTCH 1	3				
15	BK6-E6774-00	WASHER	3				
16	BK6-E6352-00	PLATE, PRESSURE 2	1				
17	BK6-E6337-00	SCREW, SPRING	3				
18	3C1-E6358-00	PLATE, PUSH	1				
19	3C1-E6356-10	ROD, PUSH 1	1				
20	54B-E6144-00	WASHER	1				
21	3C1-E6344-00	NUT, ADJUSTING	1				
22	90215-14802	WASHER, LOCK	1				
23	90170-14801	NUT	1				
24	BK7-E6380-00	PUSH LEVER ASSY	1				
25	BK6-E6345-00	SPRING, RETURN	1				
26	1PA-E6357-00	ROD, PUSH 2	1				
27	93505-16844	BALL	1				



B7D1431-U130



B7D1431-U140

FIG. 14 TRANSMISSION

REF. NO.	PART NO.	DESCRIPTION	BHM2				REMARKS
1	BK6-E7411-00	AXLE, MAIN	1				
2	BK6-E7151-00	GEAR, 5TH PINION (23T)	1				
3	90209-17285	WASHER	1				
4	93410-20038	CIRCLIP	1				
5	5D7-E7131-00	GEAR, 3RD PINION (22T/21T)	1				
6	BK6-E7161-00	GEAR, 6TH PINION (25T)	1				
7	3C1-E7121-00	GEAR, 2ND PINION (16T)	1				
8	93306-054XF	BEARING	1				
9	93306-252YN	BEARING	1				
10	3C1-E7471-00	PLATE, COVER	1				
11	98512-06012	SCREW, PAN HEAD	2				
12	BK6-E7421-00	AXLE, DRIVE	1				
13	3C1-E7211-00	GEAR, 1ST WHEEL (34T)	1				
14	90387-17804	COLLAR	1				
15	BK6-E7251-00	GEAR, 5TH WHEEL (22T)	1				
16	90209-18208	WASHER	1				
17	93410-22039	CIRCLIP	1				
18	BK6-E7241-00	GEAR, 4TH WHEEL (24T)	1				
19	BK6-E7231-00	GEAR, 3RD WHEEL (30T)	1				
20	5D7-E7261-00	GEAR, 6TH WHEEL (21T)	1				
21	BK6-E7221-00	GEAR, 2ND WHEEL (30T)	1				
22	90201-22793	WASHER, PLATE	1				
23	93410-22039	CIRCLIP	1				
24	90201-173F4	WASHER, PLATE	1				
25	93306-253X2	BEARING	1				
26	93306-272YC	BEARING	1				
27	93102-22827	OIL SEAL	1				

FIG. 16 SHIFT SHAFT

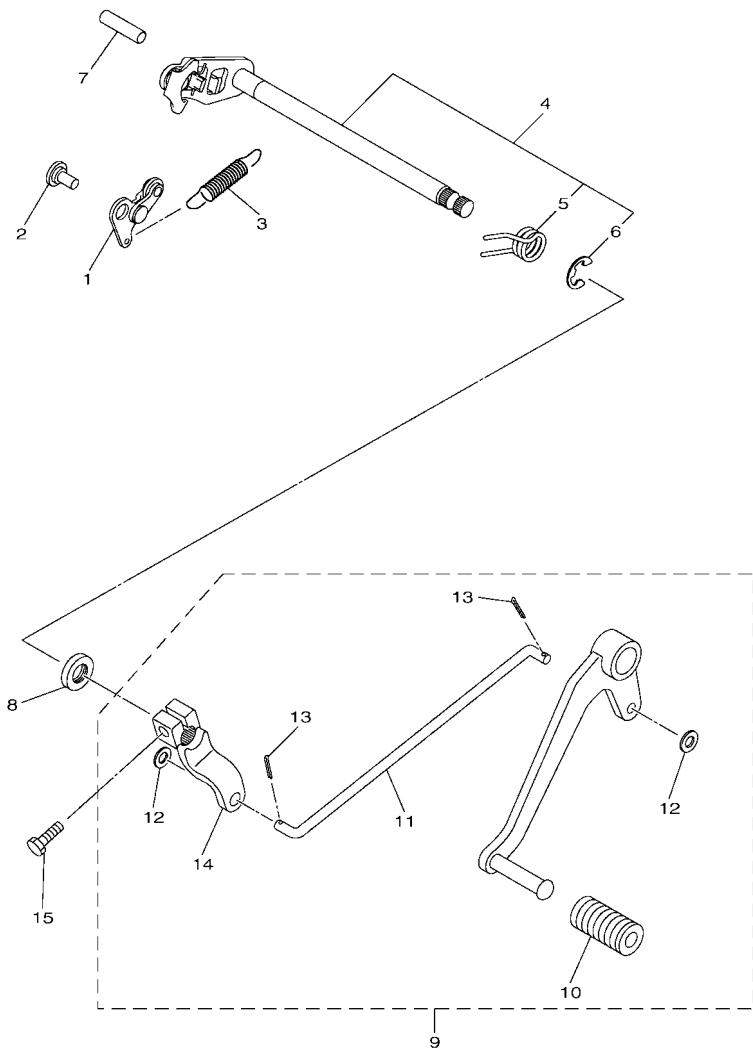

B7D1431-U160

REF. NO.	PART NO.	DESCRIPTION	BHM2				REMARKS
1	BK7-E8140-00	STOPPER LEVER ASSY	1				
2	90109-06279	BOLT	1				
3	BK6-E8337-00	SPRING	1				
4	38B-E8101-00	SHIFT SHAFT ASSY	1				
5	90508-32837	.SPRING, TORSION	1				
6	99001-10600	.CIRCLIP	1				
7	93608-30839	PIN, DOWEL	1				
8	93102-12891	OIL SEAL	1				
9	B9D-E8110-00	SHIFT PEDAL ASSY	1				
10	20P-E8113-00	.COVER, SHIFT PEDAL	1				
11	B9D-E8115-00	.ROD, SHIFT	1				
12	92902-06200	.WASHER	2				
13	90252-18800	.PIN, COTTER	2				
14	BK7-E8112-00	.ARM, SHIFT	1				
15	97012-06020	BOLT	1				

FIG. 17 FRAME

REF. NO.	PART NO.	DESCRIPTION	BHM2				REMARKS
1	B8D-F1110-02	FRAME COMP.	1				
2	90105-10225	BOLT, FLANGE	2				
3	90105-10886	BOLT, FLANGE	2				
4	90179-10805	NUT	2				
5	BK6-F2327-00	MUD GUARD 1	1				
6	90480-01558	GROMMET	4				
7	B8D-F111D-00	SEAL 1	1				
8	B8D-F8100-00	TOOL KIT	1				
9	90465-13M24	CLAMP	1				
10	55C-F815P-00	LABEL, NOTICE 1	1				

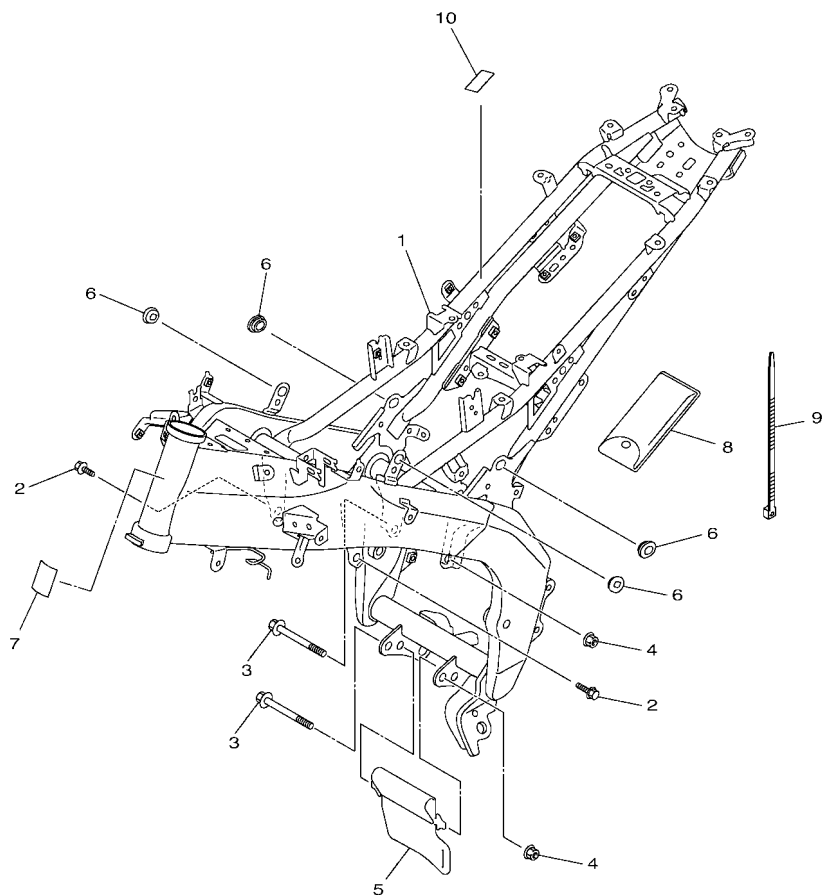

BHM1440-W170

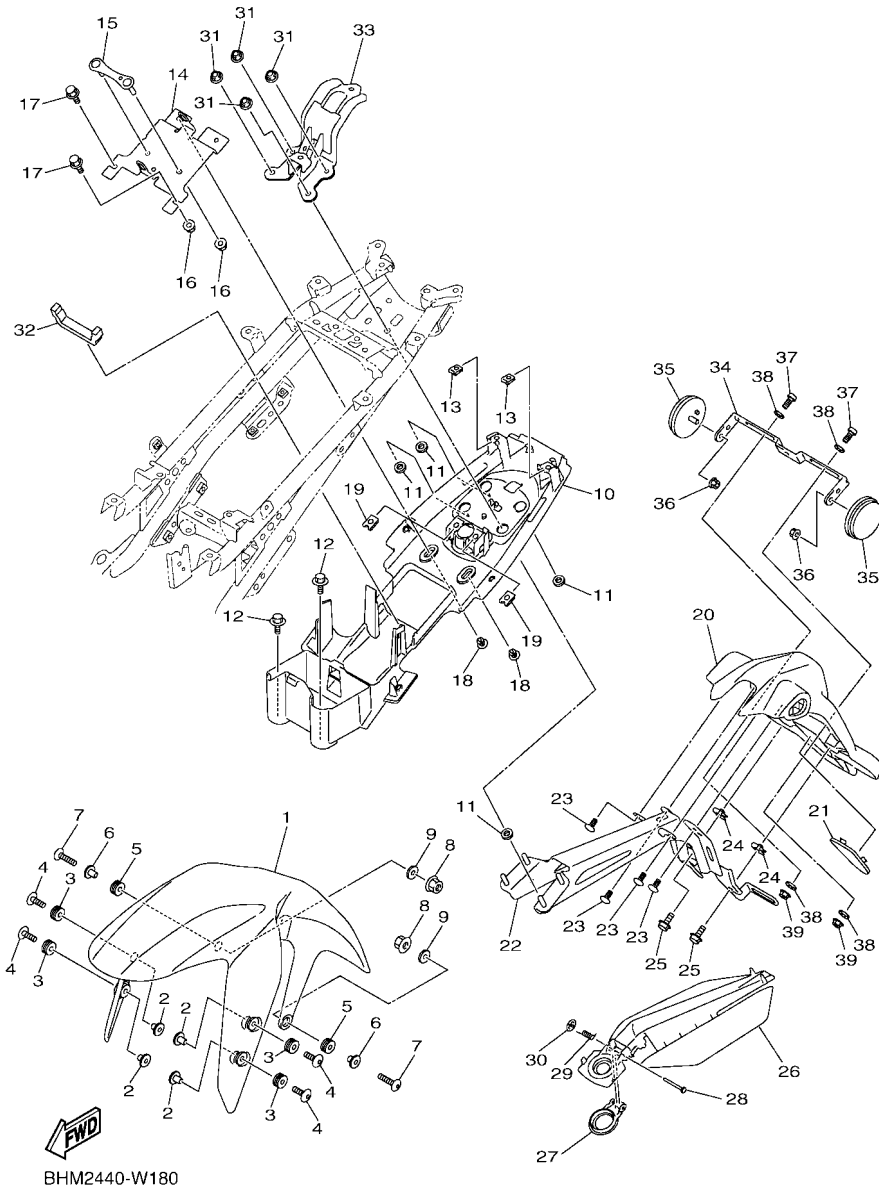
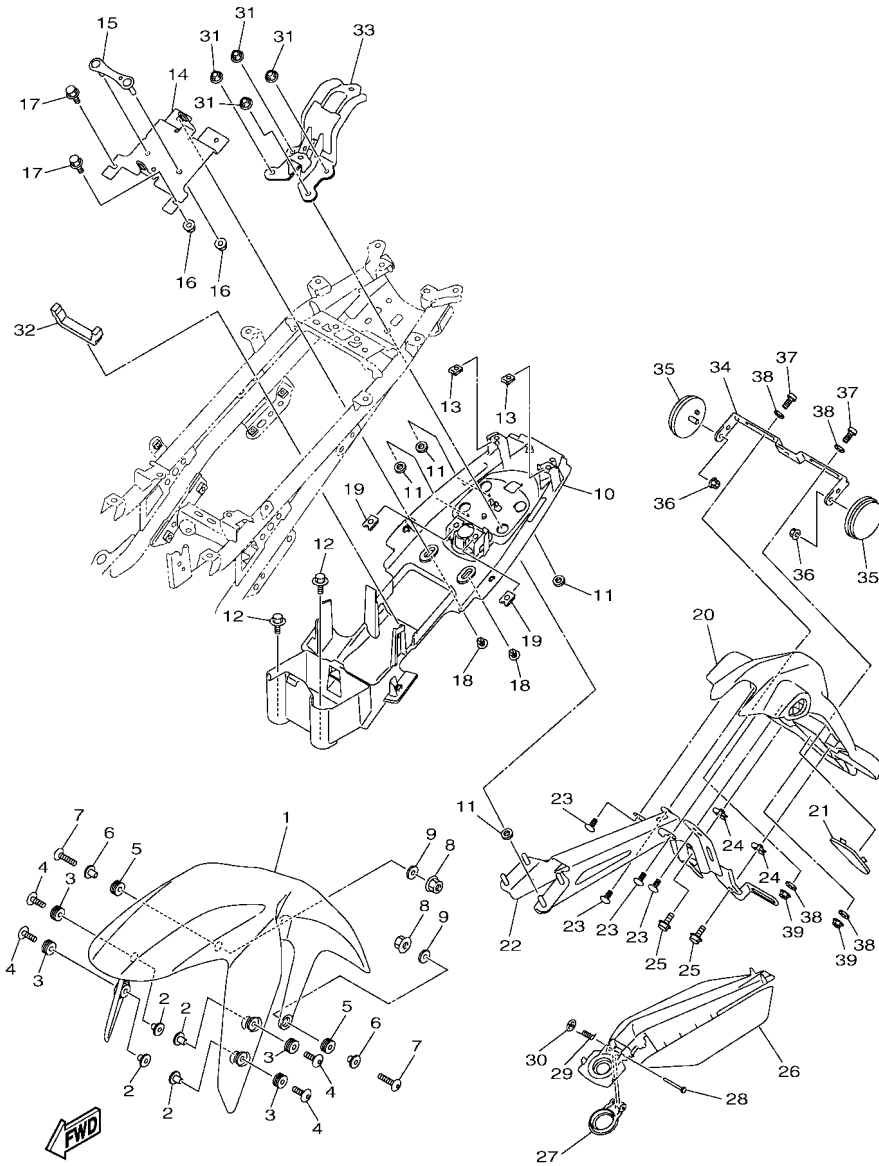

FIG. 18 FENDER

REF. NO.	PART NO.	DESCRIPTION	BHM2	REMARKS
1	BG7-F1511-00-P4	FENDER, FRONT	1	UR FOR DPBMC
	BG7-F1511-00-P5	FENDER, FRONT	1	UR FOR PGD,MDNM8
2	90387-06205	COLLAR	4	
3	90480-12805	GROMMET	4	
4	90111-06137	BOLT,HEX. SOCKET BUTTON	4	
5	90480-12072	GROMMET	2	
6	90387-068P5	COLLAR	2	
7	90111-06847	BOLT,HEX. SOCKET BUTTON	2	
8	95702-06500	NUT, FLANGE	2	
9	90201-06029	WASHER, PLATE	2	
10	B7D-F1611-00	FENDER, REAR	1	
11	90560-08326	SPACER	4	
12	90109-06220	BOLT	2	
13	90183-05807	NUT, SPRING	2	
14	B7D-H1975-00	PLATE, RECTIFIER FITTING	1	
15	B8D-F1682-00	STAY, PLATE	1	
16	95607-06200	NUT, SELF U-FLANGE	2	
17	95822-06012	BOLT, FLANGE	2	
18	90269-06816	RIVET	2	
19	90183-06800	NUT, SPRING	2	
20	B7D-F1629-00	GUARD, MUD	1	
21	B8D-F163E-00	COVER, REAR FENDER 2	1	
22	B8D-F1640-00	REAR STAY COMP.	1	
23	97702-50016	SCREW,TAPPING	4	
24	90183-050A7	NUT, SPRING	2	
25	90119-05071	BOLT, WITH WASHER	2	
26	B7D-F163A-01	COVER, REAR FENDER 1	1	



BHM2440-W180

FIG. 18 FENDER

REF. NO.	PART NO.	DESCRIPTION	BHM2				REMARKS
27	B8D-F465B-01	CAP, ROTOR	1				
28	90241-03800	PIN	1				
29	90508-09007	SPRING, TORSION	1				
30	90183-03010	NUT, SPRING	1				
31	95602-06200	NUT, SELF-LOCKING	4				
32	90520-08804	DAMPER, PLATE	1				
33	B8D-F1391-00	BRACKET, SEAT	1				
34	B2S-F1641-01	BRACKET, REFLECTOR	1				
35	2FC-H5111-00	REFLECTOR, 1	2				
36	95707-05500	NUT, FLANGE	2				
37	98507-06020	SCREW, PAN HEAD	2				
38	90201-06557	WASHER, PLATE	4				
39	95602-06200	NUT, SELF-LOCKING	2				

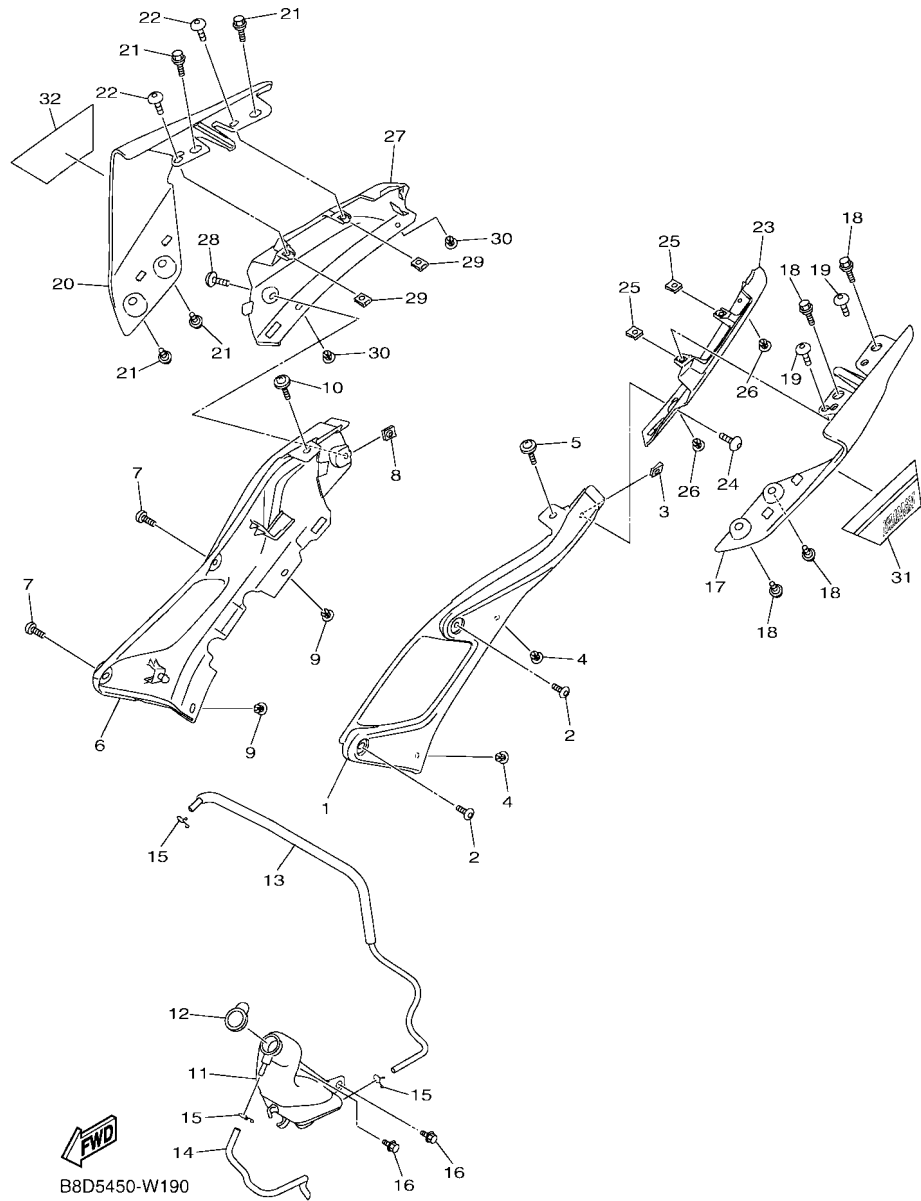
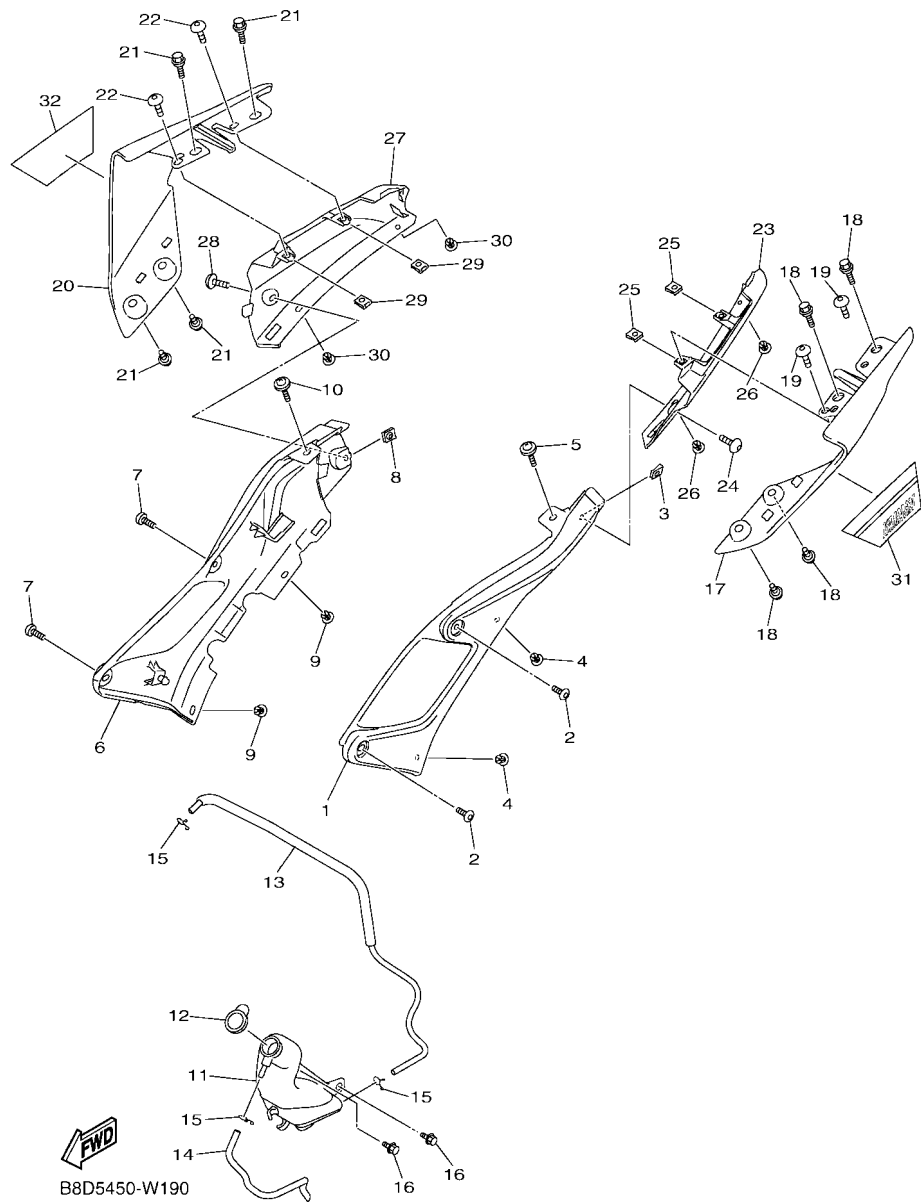

FIG. 19 SIDE COVER

REF. NO.	PART NO.	DESCRIPTION	BHM2	REMARKS
1	B7D-F1711-00	COVER, SIDE 1	1	
2	90111-06856	BOLT,HEX. SOCKET BUTTON	2	
3	90183-05807	NUT, SPRING	1	
4	90269-06816	RIVET	2	
5	90159-06860	SCREW, WITH WASHER	1	
6	B7D-F1721-00	COVER, SIDE 2	1	
7	90111-06856	BOLT,HEX. SOCKET BUTTON	2	
8	90183-05807	NUT, SPRING	1	
9	90269-06816	RIVET	2	
10	90159-06860	SCREW, WITH WASHER	1	
11	BK6-F1871-00	TANK, RECOVERY	1	
12	1S7-F1875-01	CAP	1	
13	BK7-F1817-00	PIPE 2	1	
14	BK6-F247A-01	HOSE 1	1	
15	90467-08003	CLIP	3	
16	90109-06220	BOLT	2	
17	B8D-F1731-00-P5	COVER, SIDE 3	1	MDNM8
18	90109-068B2	BOLT	4	
19	97707-50016	SCREW, TRUSS HEAD TAPPING	2	
20	B8D-F1741-00-P5	COVER, SIDE 4	1	MDNM8
21	90109-068B2	BOLT	4	
22	97707-50016	SCREW, TRUSS HEAD TAPPING	2	
23	B7D-F171E-00	COVER, SIDE 5	1	
24	97707-50016	SCREW, TRUSS HEAD TAPPING	1	
25	90183-05807	NUT, SPRING	2	
26	90269-06816	RIVET	2	
27	B7D-F171X-00	COVER, SIDE 6	1	

FIG. 19 SIDE COVER



REF. NO.	PART NO.	DESCRIPTION	BHM2	REMARKS
28	97707-50016	SCREW, TRUSS HEAD TAPPING	1	
29	90183-05807	NUT, SPRING	2	
30	90269-06816	RIVET	2	
31	B8D-F173E-00	GRAPHIC 1	1	UR FOR DPBMC
	B8D-F173E-10	GRAPHIC 1	1	UR FOR PGD
	B8D-F173E-20	GRAPHIC 1	1	UR FOR MDNM8
32	B8D-F173F-00	GRAPHIC 2	1	UR FOR DPBMC
	B8D-F173F-10	GRAPHIC 2	1	UR FOR PGD
	B8D-F173F-20	GRAPHIC 2	1	UR FOR MDNM8

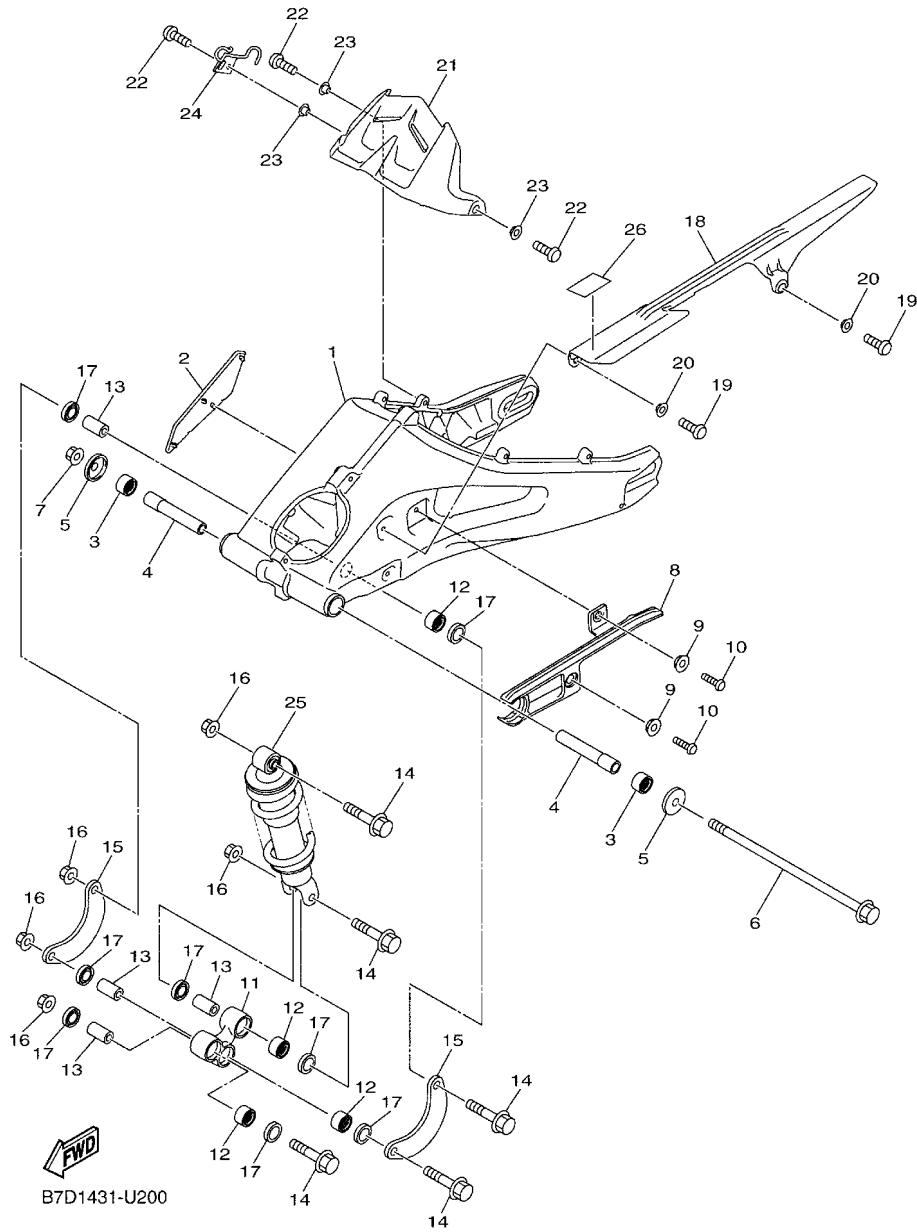
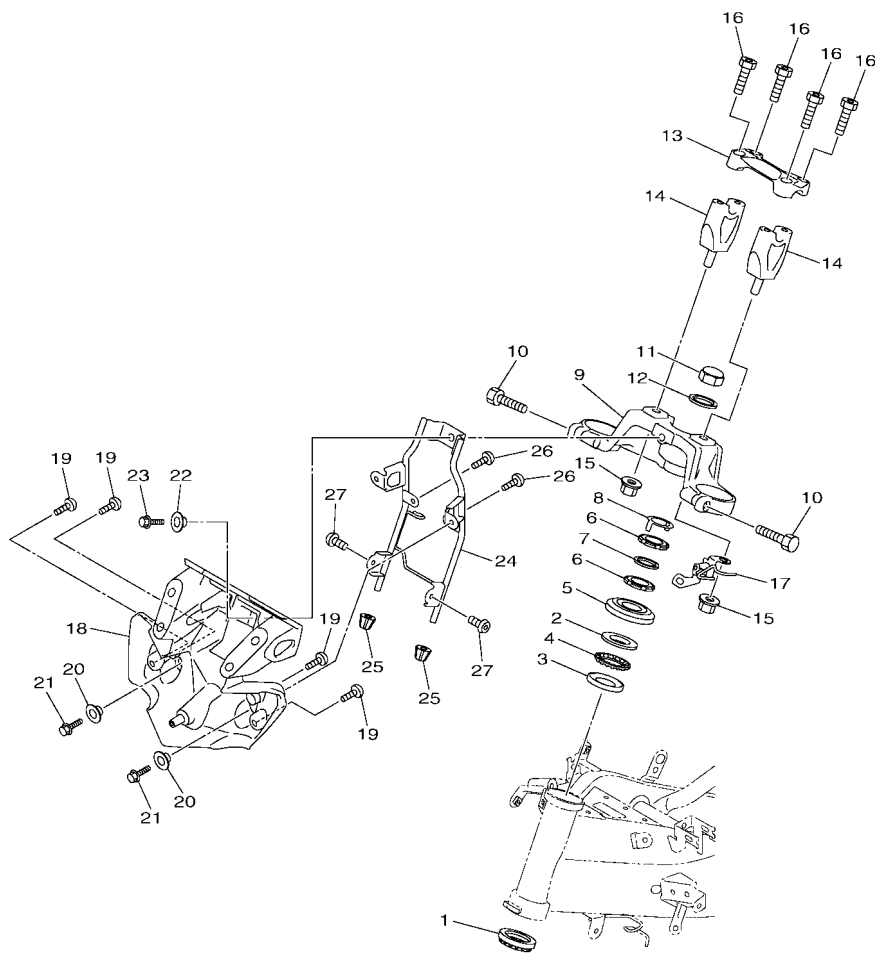

FIG. 20 REAR ARM & SUSPENSION

REF. NO.	PART NO.	DESCRIPTION	BHM2				REMARKS
1	BK6-F2110-00	REAR ARM COMP.	1				
2	BK7-F135F-00	COVER	1				
3	93317-218Y1	BEARING	2				
4	BK6-F2184-00	BUSH	2				
5	2PK-F2128-01	COVER, THRUST 1	2				
6	BK6-F2141-00	SHAFT, PIVOT	1				
7	95602-12200	NUT, SELF-LOCKING	1				
8	BK7-F2151-00	SEAL, GUARD	1				
9	90387-068S1	COLLAR	2				
10	92012-06016	BOLT, BUTTON HEAD	2				
11	1CK-F217A-00	ARM, RELAY	1				
12	93315-317Y1	BEARING	4				
13	90387-10814	COLLAR	4				
14	90105-10887	BOLT, FLANGE	5				
15	2PK-F217F-00	ROD, CONNECTING 1	2				
16	90179-10805	NUT	5				
17	93106-17801	OIL SEAL	8				
18	BK6-F2311-00	CASE, CHAIN	1				
19	92012-06016	BOLT, BUTTON HEAD	2				
20	90387-068S1	COLLAR	2				
21	BK7-F1650-00	REAR FENDER COMP.	1				
22	92012-06016	BOLT, BUTTON HEAD	3				
23	90387-068S1	COLLAR	3				
24	BK6-F587A-00	HOLDER, BRAKE HOSE 4	1				
25	B7D-F2210-00	SHOCK ABSORBER ASSY, REAR	1				
26	B8D-F1668-00	LABEL, TIRE	1				

FIG. 21 STEERING



B7D1431-U210

REF. NO.	PART NO.	DESCRIPTION	BHM2				REMARKS
1	5BP-F3873-01	BEARING, STEERING UPPER	1				
2	4FP-F3411-20	RACE, BALL 1	1				
3	4FP-F3412-10	RACE, BALL 2	1				
4	5VL-F341E-10	RETAINER, BALL BEARING	1				
5	5BP-F3416-10	COVER, BALL RACE 2	1				
6	90179-25615	NUT	2				
7	90202-26142	WASHER, PLATE	1				
8	1PA-F3418-00	WASHER, SPECIAL	1				
9	B8D-F3435-00	CROWN, HANDLE	1				
10	91317-08035	BOLT,HEX.SOCKET HEAD	2				
11	90176-22081	NUT, CAP	1				
12	90201-220T0	WASHER, PLATE	1				
13	B48-F3441-00	HOLDER, HANDLE UPPER	1				
14	B48-F3442-01	HOLDER, HANDLE LOWER	2				
15	90185-10815	NUT, SELF-LOCKING	2				
16	91317-08030	BOLT,HEX.SOCKET HEAD	4				
17	B8D-F3175-00	BRACKET, HEADLIGHT STAY 1	1				
18	B8D-H4130-00	BODY ASSY, HEADLIGHT	1				
19	97707-50012	SCREW, TRUSS HEAD TAPPING	4				
20	90387-068S1	COLLAR	2				
21	95027-06014	BOLT, FLANGE	2				
22	90387-08079	COLLAR	1				
23	95022-08020	BOLT, FLANGE	1				
24	B8D-F3174-00	STAY, HEADLIGHT	1				
25	BG7-F317J-00	DAMPER 1	2				
26	90154-05041	SCREW, BINDING	2				
27	90111-05003	BOLT,HEX. SOCKET BUTTON	2				

FIG. 22 FRONT FORK

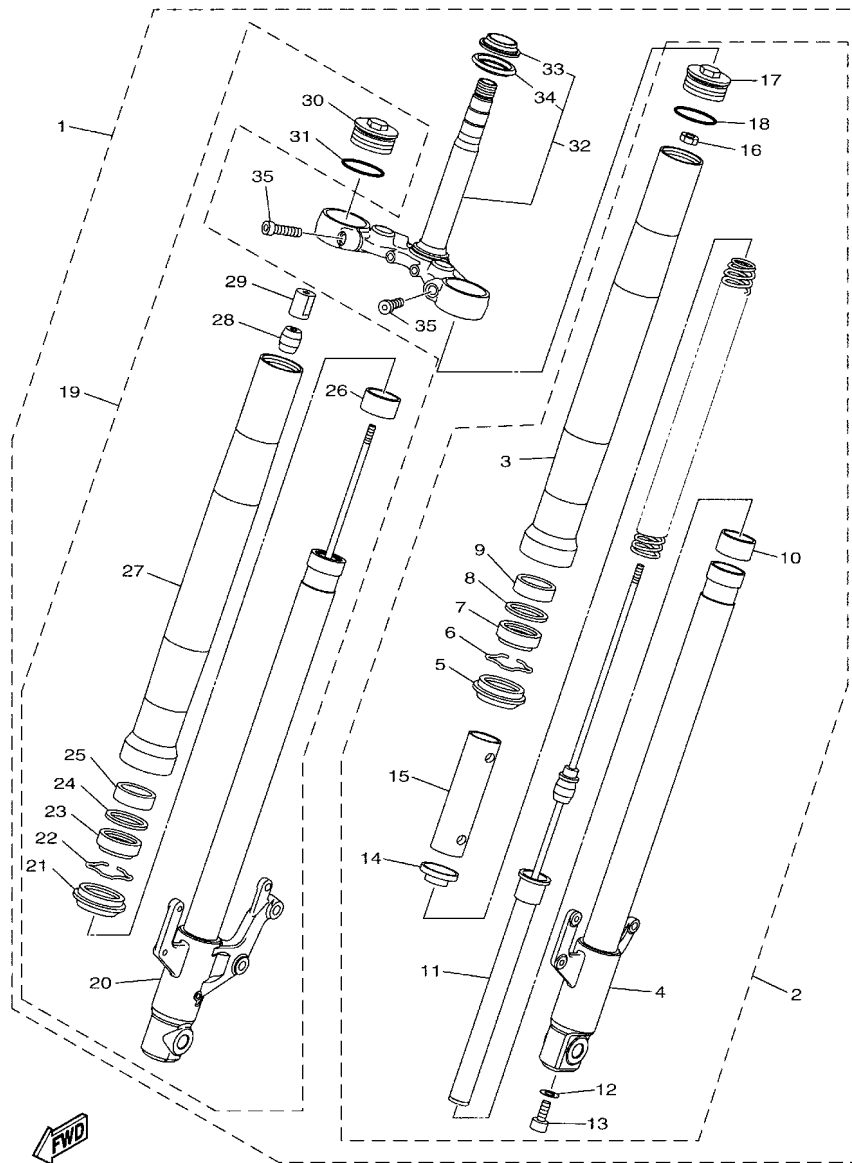

B7D1431-U220

REF. NO.	PART NO.	DESCRIPTION	BHM2				REMARKS
1	B7D-F3100-00	FRONT FORK ASSY	1				
2	B7D-F3102-00	.FRONT FORK ASSY (L.H)	1				
3	B7D-F3126-00	..TUBE, OUTER	1				
4	B7D-F3110-00	..INNER TUBE COMP.1	1				
5	B48-F3144-00	..SEAL, DUST	1				
6	B48-F3156-00	..RING, SNAP	1				
7	BK6-F3145-00	..OIL SEAL	1				
8	B48-F3146-00	..WASHER, OIL SEAL	1				
9	31A-23125-31	..METAL, SLIDE 1	1				
10	B48-F3171-00	..PISTON, FRONT FORK	1				
11	B7D-F3170-00	..CYLINDER COMP., FRONT FORK	1				
12	B48-F3158-00	..GASKET	1				
13	4TU-F3356-00	..BOLT 2	1				
14	B7D-F3117-00	..GUIDE, SPRING	1				
15	B7D-F3118-00	..SPACER	1				
16	B7D-F3357-00	..NUT	1				
17	B48-F3111-00	..BOLT, CAP	1				
18	B48-F3147-00	..O-RING	1				
19	B7D-F3103-00	..FRONT FORK ASSY (R.H)	1				
20	B7D-F3120-00	..INNER TUBE COMP.2	1				
21	B48-F3144-00	..SEAL, DUST	1				
22	B48-F3156-00	..RING, SNAP	1				
23	BK6-F3145-00	..OIL SEAL	1				
24	B48-F3146-00	..WASHER, OIL SEAL	1				
25	31A-23125-31	..METAL, SLIDE 1	1				
26	B48-F3171-00	..PISTON, FRONT FORK	1				
27	B7D-F3126-00	..TUBE, OUTER	1				

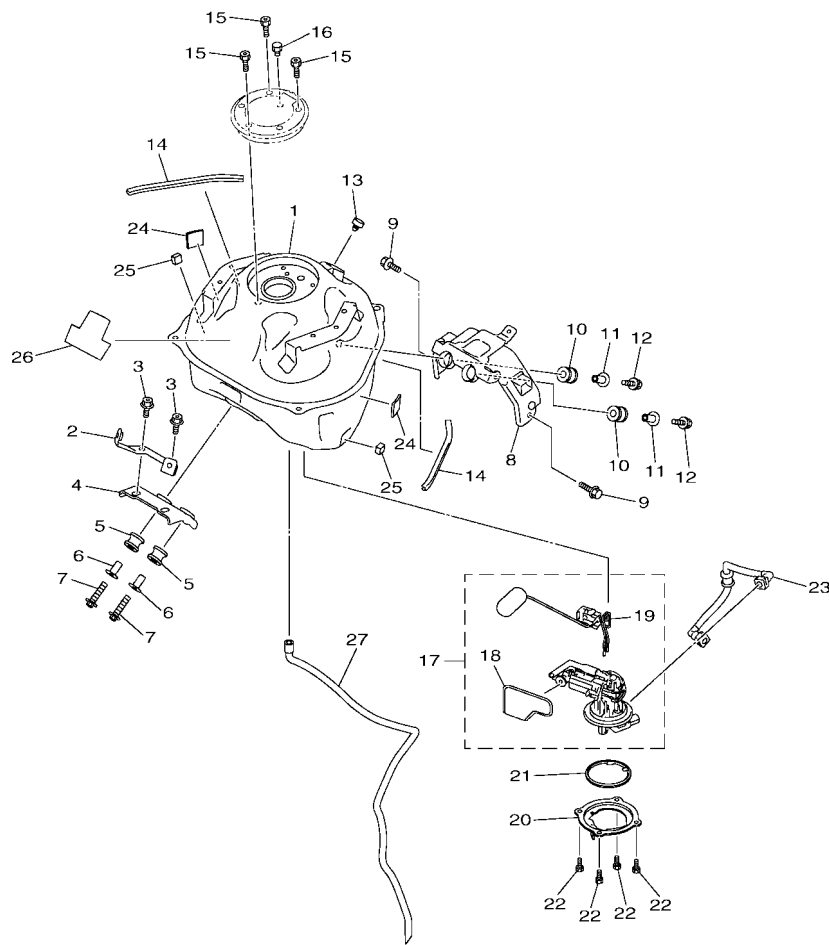
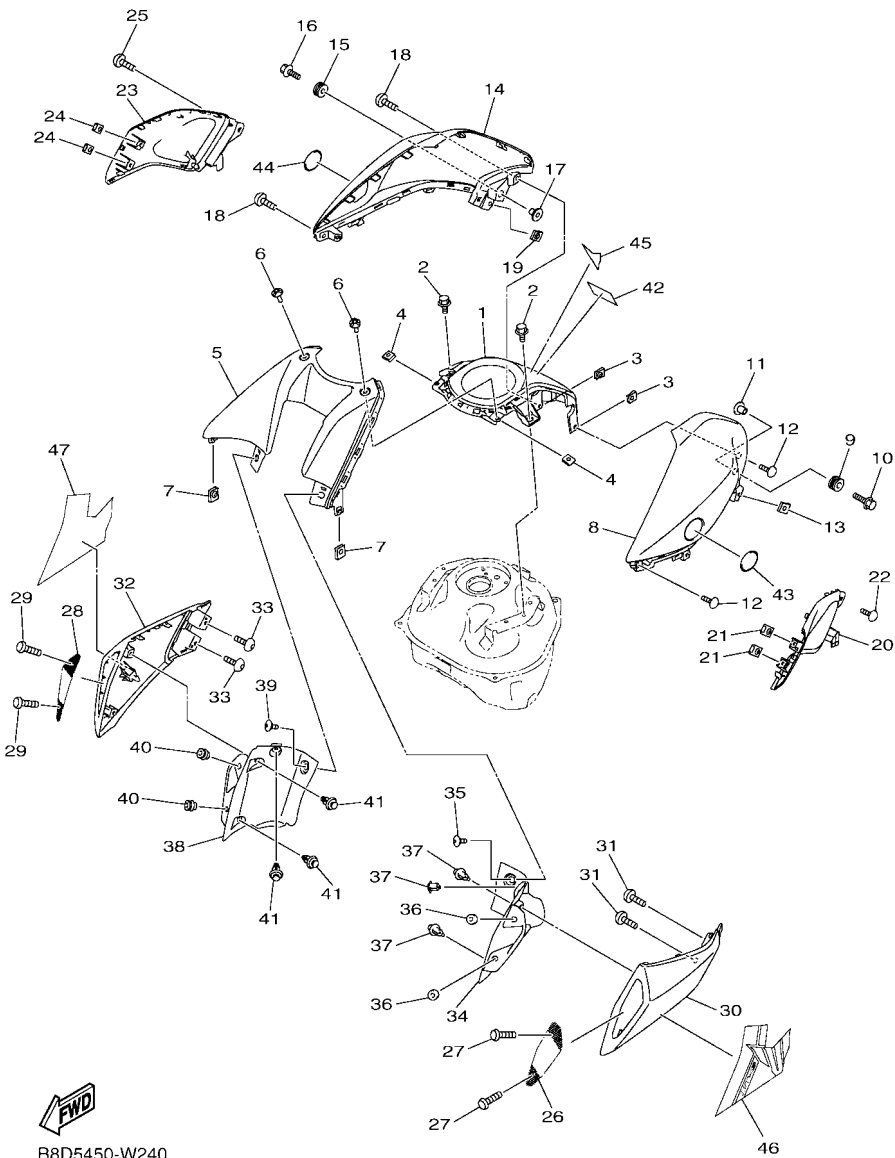

FIG. 23 FUEL TANK

REF. NO.	PART NO.	DESCRIPTION	BHM2				REMARKS
1	B8D-F4110-00	FUEL TANK COMP.	1				
2	B8D-F411F-00	PLATE, FITTING	1				
3	90110-08052	BOLT, HEXAGON SOCKET HEAD	2				
4	B8D-F412Y-00	BRACKET, TANK FITTING	1				
5	90480-18813	GROMMET	2				
6	90387-068M3	COLLAR	2				
7	95022-06030	BOLT, FLANGE	2				
8	B8D-F4191-00	BRACKET, FUEL TANK 1	1				
9	90110-06245	BOLT, HEXAGON SOCKET HEAD	2				
10	90480-18813	GROMMET	2				
11	90387-068M3	COLLAR	2				
12	95022-06030	BOLT, FLANGE	2				
13	1PA-F1717-00	DAMPER	1				
14	B8D-F4188-00	MOLD, FUEL TANK	2				
15	90110-05806	BOLT, HEXAGON SOCKET HEAD	3				
16	91312-05010	BOLT, HEXAGON SOCKET HEAD	1				
17	B7D-E3907-00	FUEL PUMP COMP.	1				
18	54P-E3915-00	.FILTER, FUEL SUCTION	1				
19	B7D-H5752-00	.SENDER UNIT ASSY, FUEL METER	1				
20	BK6-F4491-00	BRACKET, FUEL PUMP	1				
21	54P-F414G-10	SEAL	1				
22	91312-05010	BOLT, HEXAGON SOCKET HEAD	4				
23	BK6-E3971-00	PIPE, FUEL 1	1				
24	90520-03800	DAMPER, PLATE	2				
25	90520-08007	DAMPER, PLATE	2				
26	B8D-F414J-00	DAMPER, PLATE 2	1				
27	BK7-F4312-00	PIPE 2	1				



BHM1440-W230



B8D5450-W240

FIG. 24 FUEL TANK 2

REF. NO.	PART NO.	DESCRIPTION	BHM2	REMARKS
1	B8D-F41B1-00-P1	COVER, TANK	1	UR FOR DPBMC
	B8D-F41B1-00-P2	COVER, TANK	1	UR FOR PGD
	B8D-F41B1-00-P3	COVER, TANK	1	UR FOR MDNM8
2	90109-06202	BOLT	2	
3	90183-05807	NUT, SPRING	2	
4	90183-050A7	NUT, SPRING	2	
5	B7D-F836K-00	PANEL, INNER 1	1	
6	90111-05817	BOLT, HEX. SOCKET BUTTON	2	
7	90183-05807	NUT, SPRING	2	
8	B8D-F4129-00-P3	COVER, SIDE 1	1	UR FOR DPBMC
	B8D-F4129-00-3E	COVER, SIDE 1	1	UR FOR PGD
	B8D-F4129-00-P5	COVER, SIDE 1	1	UR FOR MDNM8
9	90480-12808	GROMMET	1	
10	90119-06810	BOLT, WITH WASHER	1	
11	90387-06899	COLLAR	1	
12	97702-50016	SCREW, TAPPING	2	
13	90183-05807	NUT, SPRING	1	
14	B8D-F4139-00-P3	COVER, SIDE 2	1	UR FOR DPBMC
	B8D-F4139-00-3E	COVER, SIDE 2	1	UR FOR PGD
	B8D-F4139-00-P5	COVER, SIDE 2	1	UR FOR MDNM8
15	90480-12808	GROMMET	1	
16	90119-06810	BOLT, WITH WASHER	1	
17	90387-06899	COLLAR	1	
18	97702-50016	SCREW, TAPPING	2	
19	90183-05807	NUT, SPRING	1	
20	B7D-F4121-00	SEAT, KNEE GRIP 1	1	
21	90183-05807	NUT, SPRING	2	

FIG. 24 FUEL TANK 2

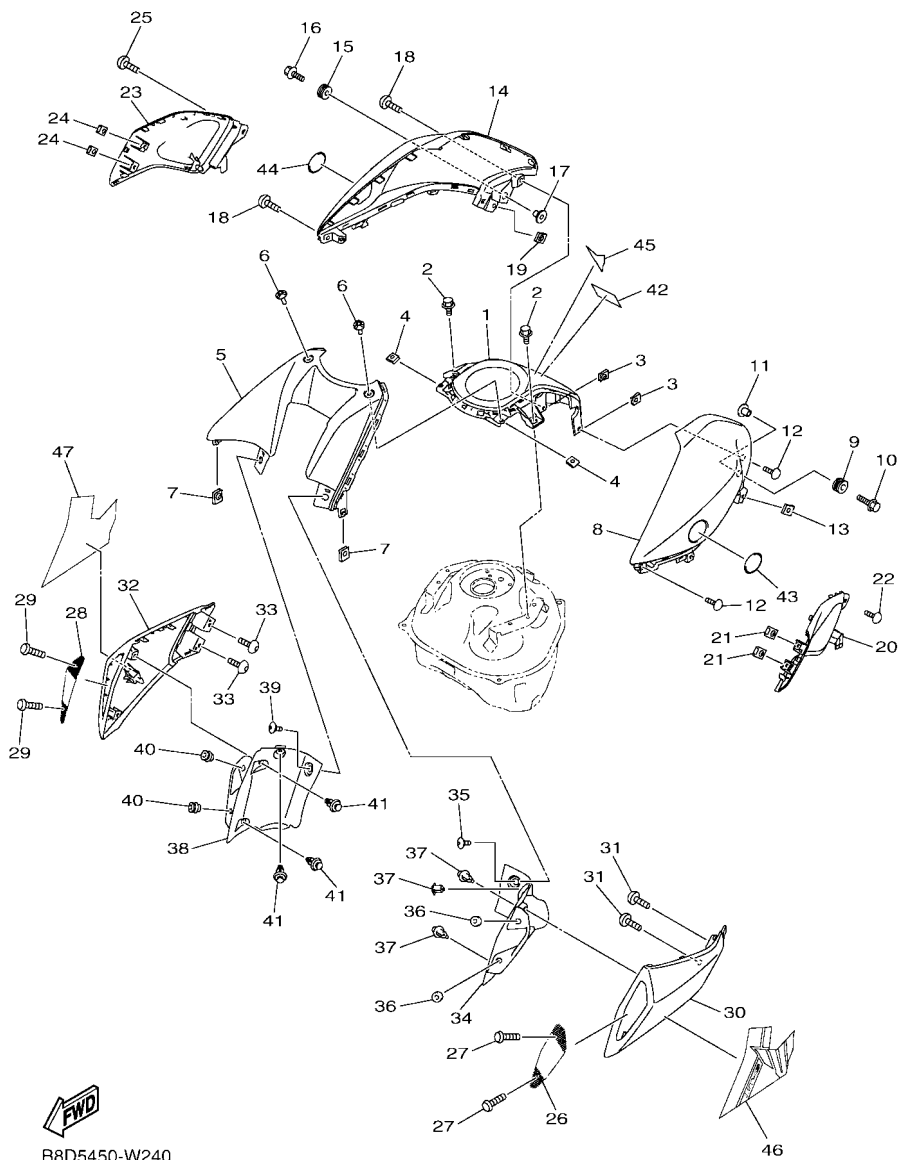

B8D5450-W240

REF. NO.	PART NO.	DESCRIPTION	BHM2				REMARKS
22	97702-50016	SCREW,TAPPING	1				
23	B7D-F4122-00	SEAT, KNEE GRIP 2	1				
24	90183-05807	NUT, SPRING	2				
25	97702-50016	SCREW,TAPPING	1				
26	B7D-F837V-00	GRILL, AIR OUTLET 1	1				
27	92017-05016	BOLT, BUTTON HEAD	2				
28	B7D-F837W-00	GRILL, AIR OUTLET 2	1				
29	92017-05016	BOLT, BUTTON HEAD	2				
30	B8D-F137W-00-P1	SCOOP, AIR 1	1				UR FOR DPBMC
	B8D-F137W-00-3E	SCOOP, AIR 1	1				UR FOR PGD
	B8D-F137W-00-P2	SCOOP, AIR 1	1				UR FOR MDNM8
31	97702-50012	SCREW, TAPPING	2				
32	B8D-F137X-00-P1	SCOOP, AIR 2	1				UR FOR DPBMC
	B8D-F137X-00-3E	SCOOP, AIR 2	1				UR FOR PGD
	B8D-F137X-00-P2	SCOOP, AIR 2	1				UR FOR MDNM8
33	97702-50012	SCREW, TAPPING	2				
34	B7D-F836L-00	PANEL, INNER 2	1				
35	90109-068C3	BOLT	1				
36	90179-05849	NUT	2				
37	90269-06816	RIVET	3				
38	B7D-F836M-00	PANEL, INNER 3	1				
39	90109-068C3	BOLT	1				
40	90179-05849	NUT	2				
41	90269-06816	RIVET	3				
42	B17-F1568-00	LABEL, WARNING	1				
43	2DP-F413B-00	EMBLEM	1				
44	2DP-F413B-00	EMBLEM	1				

FIG. 24 FUEL TANK 2

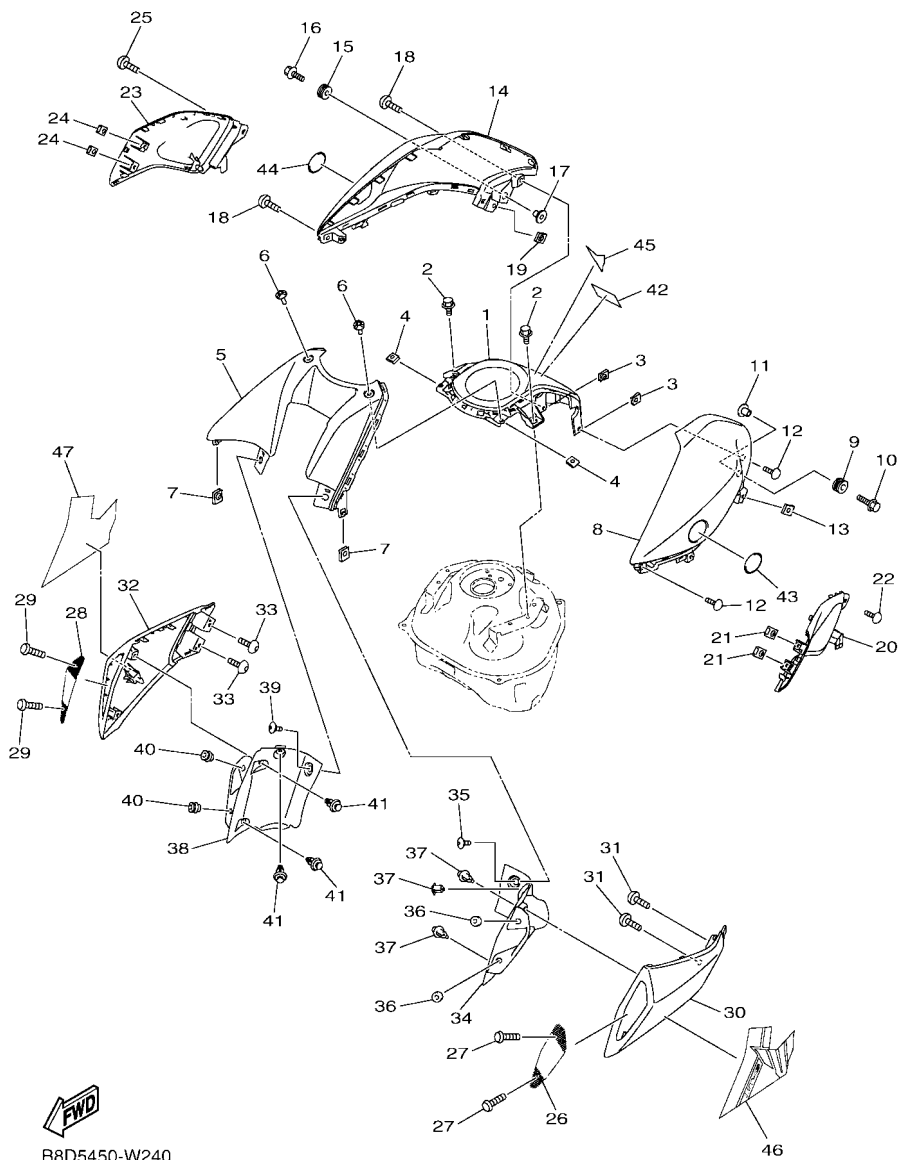

B8D5450-W240

REF. NO.	PART NO.	DESCRIPTION	BHM2				REMARKS
45	B04-F4254-A0	GRAPHIC, FUEL TANK 7	1				UR FOR DPBMC
	B04-F4254-D0	GRAPHIC, FUEL TANK 7	1				UR FOR PGD
	B04-F4254-E0	GRAPHIC, FUEL TANK 7	1				UR FOR MDNM8
46	B8D-F8393-40	GRAPHIC 3	1				UR FOR DPBMC
	B8D-F8393-50	GRAPHIC 3	1				UR FOR PGD
	B8D-F8393-60	GRAPHIC 3	1				UR FOR MDNM8
47	B8D-F8394-40	GRAPHIC 4	1				UR FOR DPBMC
	B8D-F8394-50	GRAPHIC 4	1				UR FOR PGD
	B8D-F8394-60	GRAPHIC 4	1				UR FOR MDNM8

FIG. 25 SEAT

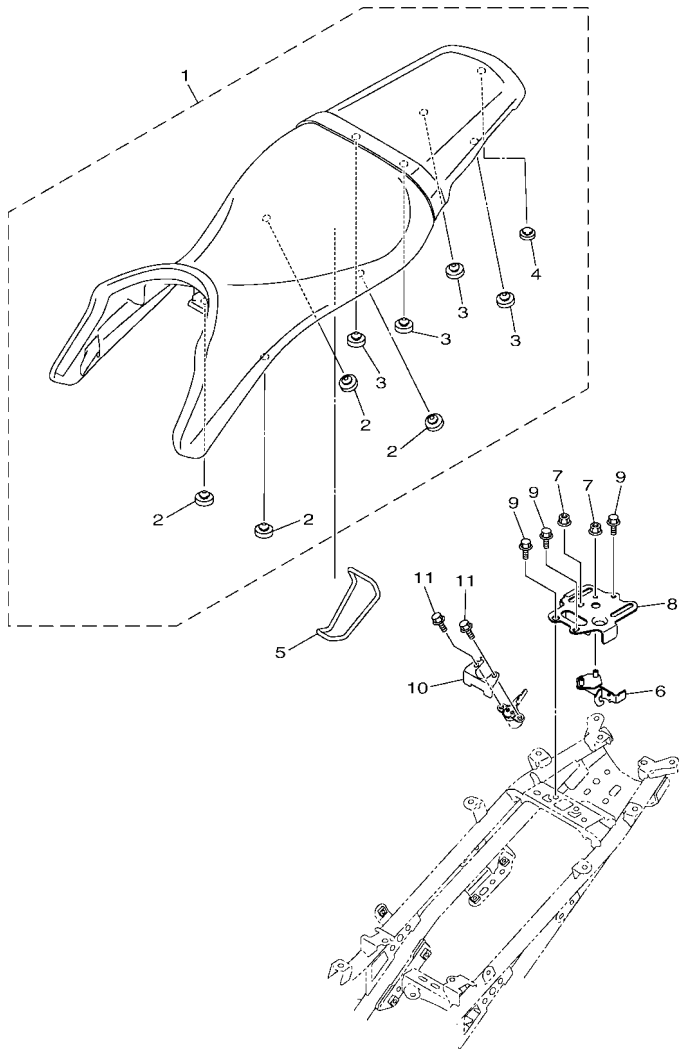

REF. NO.	PART NO.	DESCRIPTION	BHM2				REMARKS
1	B9D-F4730-00	DOUBLE SEAT ASSY	1				
2	1PM-F4741-00	.PAD, SEAT	4				
3	4LS-F4741-00	.PAD, SEAT	4				
4	B9D-F4741-00	.PAD, SEAT	1				
5	5TL-H2131-00	BAND, BATTERY	1				
6	B9D-F4780-00	SEAT LOCK ASSY	1				
7	95707-06500	NUT, FLANGE	2				
8	B8D-F478X-00	BRACKET, SEAT LOCK	1				
9	95822-06014	BOLT, FLANGE	3				
10	B8D-F479K-00	PLATE, LOCK	1				
11	95022-06016	BOLT, FLANGE	2				



BHM1440-W250

FIG. 26 FRONT WHEEL

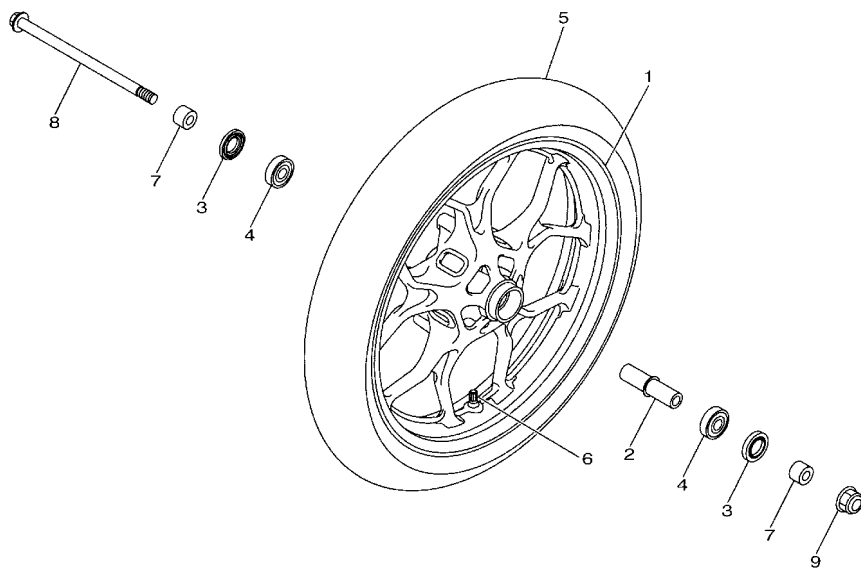

REF. NO.	PART NO.	DESCRIPTION	BHM2				REMARKS
1	1WD-F5168-03-P0	CAST WHEEL, FRONT	1				UR FOR DPBMC
	1WD-F5168-03-P2	CAST WHEEL, FRONT	1				UR FOR PGD
	1WD-F5168-03-98	CAST WHEEL, FRONT	1				UR FOR MDNM8
2	1WD-F510C-01	COLLAR ASSY.	1				
3	93106-26815	OIL SEAL	2				
4	93306-302YN	BEARING	2				
5	94111-17801	TIRE (110/70-17M/C 54S RX-01F)	1				INOUE
6	93900-00824	VALVE, RIM	1				
7	1PA-F5386-00	COLLAR, SPROCKET AXLE	2				
8	BG7-F5181-00	AXLE, WHEEL	1				
9	95602-14200	NUT, SELF-LOCKING	1				



B7D1431-U260

FIG. 27 FRONT BRAKE CALIPER

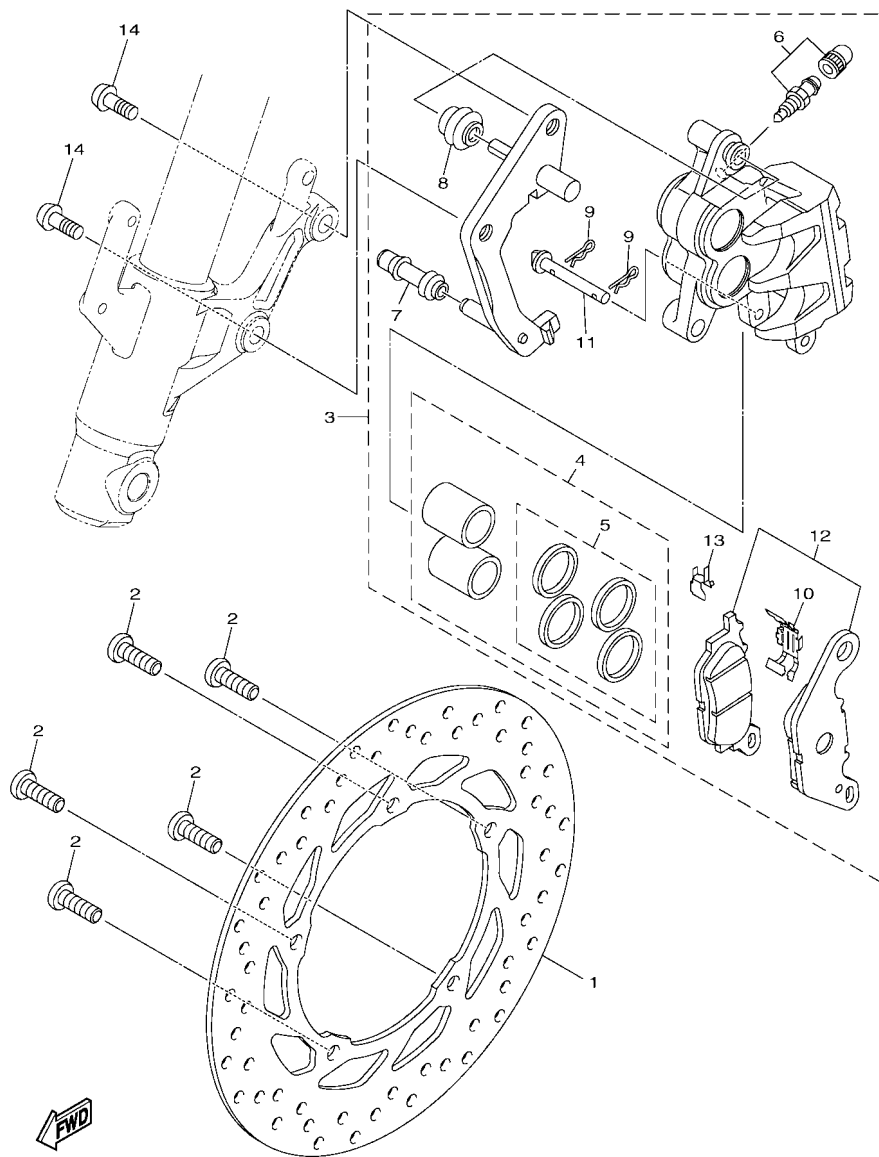

BHM1440-W270

REF. NO.	PART NO.	DESCRIPTION	BHM2				REMARKS
1	1CK-F582U-00	DISK, BRAKE (RIGHT)	1				
2	90111-08087	BOLT,HEX. SOCKET BUTTON	5				
3	B48-F580U-01	CALIPER ASSY (RIGHT)	1				
4	3C1-F5802-00	.PISTON ASSY, CALIPER	1				
5	3C1-F5803-50	..CALIPER SEAL KIT	1				
6	4C9-W0048-00	..BLEED SCREW KIT	1				
7	5YP-F5937-00	..BOOT 2	1				
8	5YP-F5917-00	..BOOT, CALIPER	1				
9	5YP-F5925-01	..CLIP	2				
10	5P0-F5919-01	..SUPPORT, PAD	1				
11	5YP-F5924-00	..PIN, PAD	1				
12	3C1-F5805-10	..BRAKE PAD KIT	1				
13	5YP-F5939-00	..CLIP, PAD	1				
14	90149-10804	SCREW	2				

FIG. 28 REAR WHEEL

REF. NO.	PART NO.	DESCRIPTION	BHM2	REMARKS
1	B7D-F5338-10	CAST WHEEL, REAR	1	UR FOR DPBMC
	B7D-F5338-30	CAST WHEEL, REAR	1	UR FOR PGD
	B7D-F5338-00	CAST WHEEL, REAR	1	UR FOR MDNM8
2	B97-F530S-00	COLLAR ASSY	1	
3	93306-252YP	BEARING	2	
4	B97-F5364-00	DAMPER	6	
5	93106-22808	OIL SEAL	1	
6	BK6-F5366-01	CLUTCH, HUB	1	
7	93306-054XC	BEARING	1	
8	93106-26815	OIL SEAL	1	
9	B97-F5376-00	COLLAR, WHEEL	1	
10	B8D-F5452-00	SPROCKET, DRIVEN (52T)	1	
11	90116-08846	BOLT, STUD	6	
12	95602-08200	NUT, U FLANGE	6	
13	BK6-F5414-00	SPACER	1	
14	94114-17802	TIRE (140/70-17M/C 66S RX-01R)	1	INOUE
15	93900-00824	VALVE, RIM	1	
16	5BP-F5381-00	AXLE, WHEEL	1	
17	B97-F5377-00	COLLAR, WHEEL	1	
18	B97-F5383-00	COLLAR, WHEEL	1	
19	95602-14200	NUT, SELF-LOCKING	1	
20	90201-15814	WASHER, PLATE	2	
21	1CK-F5388-00	PULLER, CHAIN 1	2	
22	90101-08006	BOLT	2	
23	95302-08700	NUT, HEXAGON	2	
24	94568-K1131	CHAIN	1	
25	94668-K1021	JOINT, CHAIN(DID428VIX2 ZJ)	1	

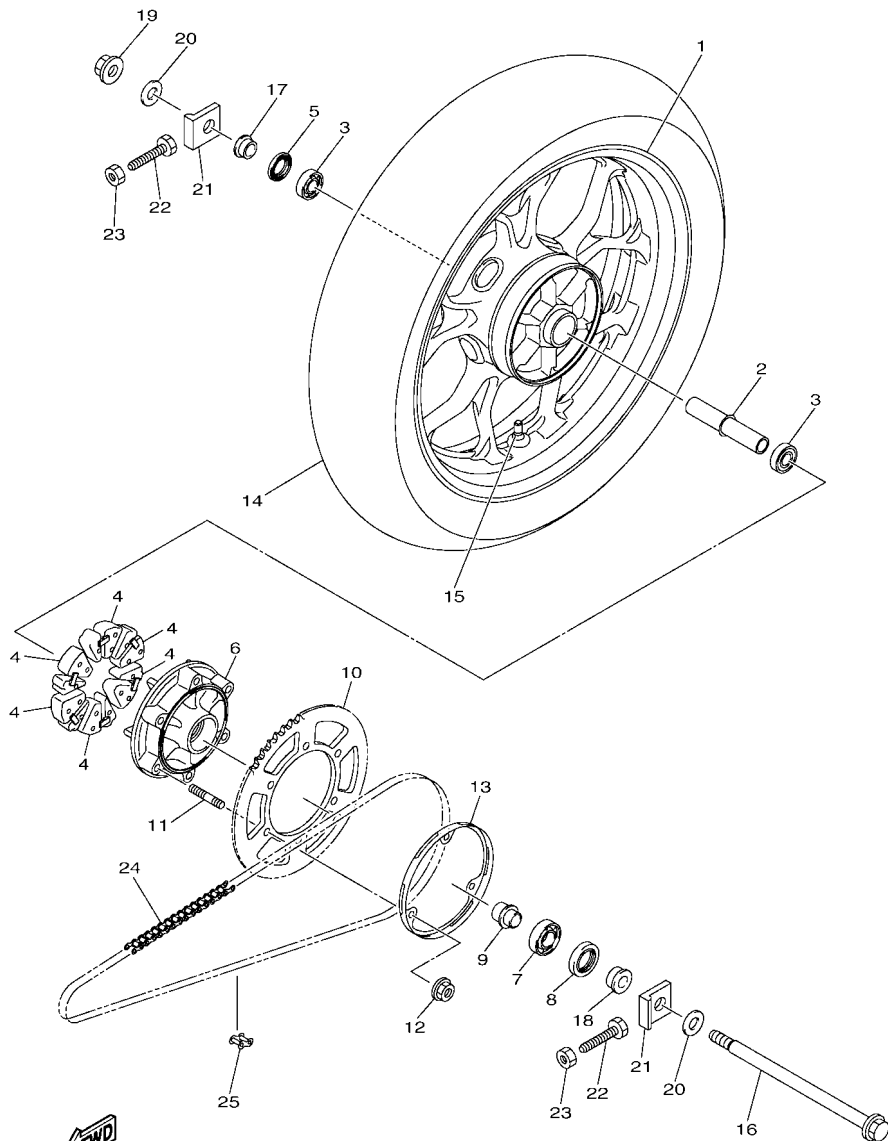

B7D1431-U280

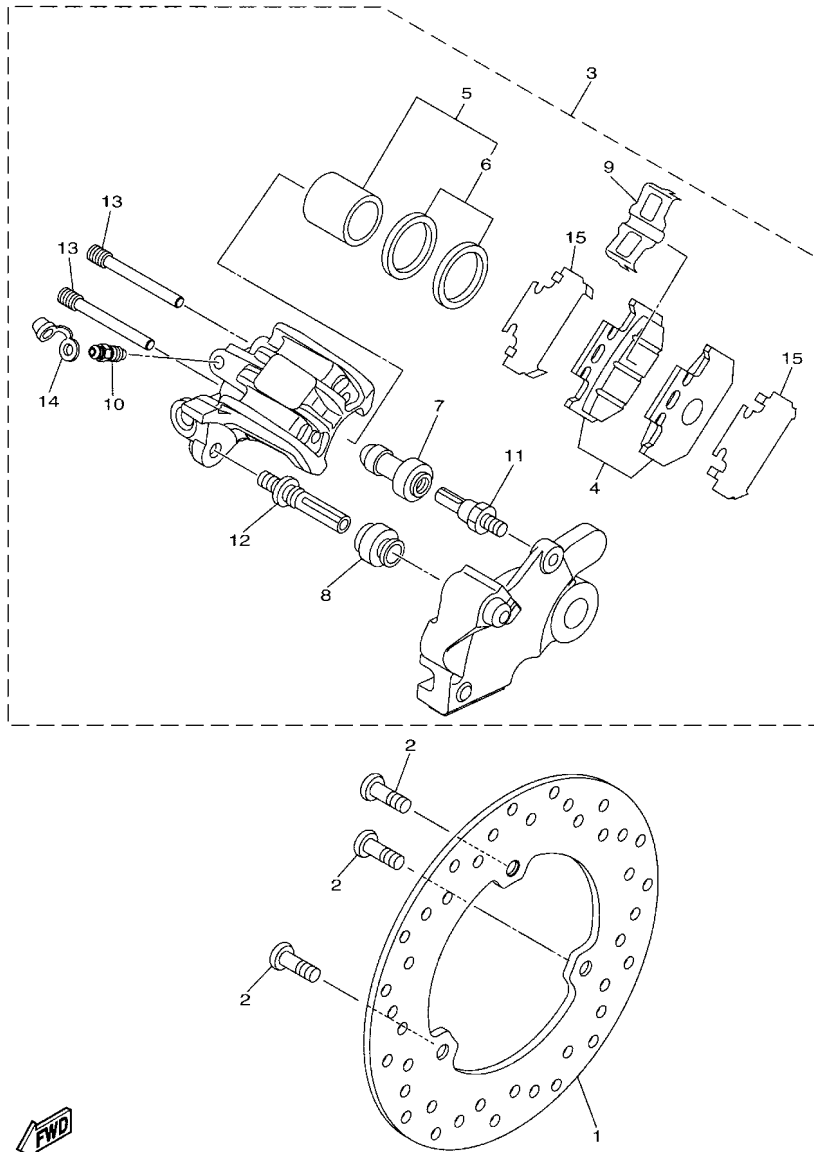

B7D1431-U290

FIG. 29 REAR BRAKE CALIPER

REF. NO.	PART NO.	DESCRIPTION	BHM2				REMARKS
1	BK6-F582W-00	DISK, REAR BRAKE 2	1				
2	90111-08089	BOLT,HEX. SOCKET BUTTON	3				
3	B97-F580W-00	CALIPER ASSY, REAR 2	1				
4	B97-F5806-00	.BRAKE PAD KIT 2	1				
5	5XT-25802-50	.PISTON ASSY, CALIPER	1				
6	3JD-25803-50	..CALIPER SEAL KIT	1				
7	5HH-F5937-00	.BOOT 2	1				
8	5HH-F5917-00	.BOOT, CALIPER	1				
9	3SP-25919-51	.SUPPORT, PAD	1				
10	5HH-F5824-00	.SCREW, BLEED	1				
11	5HH-F5914-00	.PIN, SLIDE	1				
12	3SP-25926-51	.BOLT	1				
13	3SP-25924-51	.PIN, PAD	2				
14	5HH-F5825-51	.CAP	1				
15	5XT-25827-00	.SHIM, CALIPER	2				

FIG. 30 STEERING HANDLE & CABLE

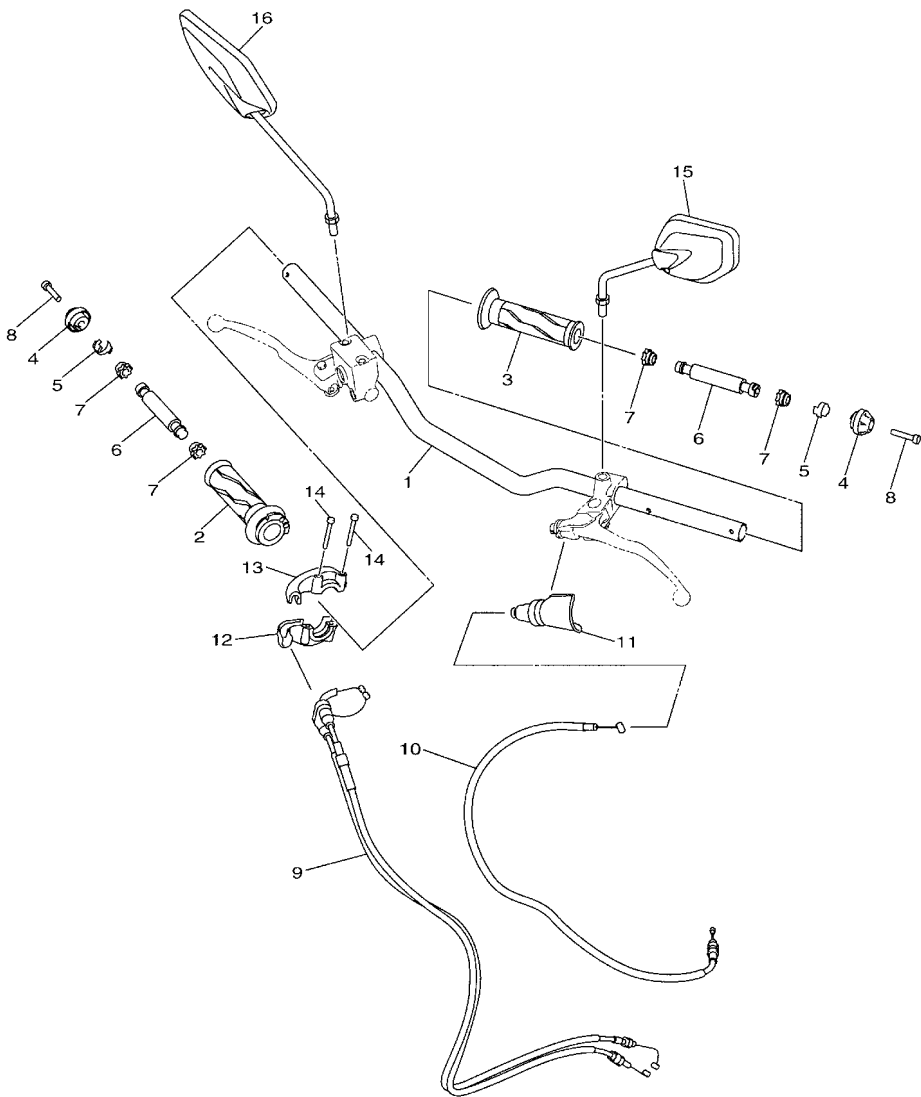

REF. NO.	PART NO.	DESCRIPTION	BHM2				REMARKS
1	B8D-F6111-00	HANDLEBAR	1				
2	1CK-F6240-01	GRIP ASSY	1				
3	20P-F6241-01	GRIP	1				
4	2PK-F6246-00	END, GRIP	2				
5	1S7-F6257-00	STOPPER	2				
6	1S7-F622H-00	WEIGHT	2				
7	1S7-F622F-00	DAMPER, LOCATING 1	4				
8	91317-06030	BOLT,HEX.SOCKET HEAD	2				
9	B8D-F6301-00	THROTTLE CABLE ASSY	1				
10	B8D-F6335-00	WIRE, CLUTCH	1				
11	3RS-F6372-00	COVER, HANDLE LEVER 1	1				
12	B7D-F6281-00	CAP, GRIP UPPER	1				
13	B7D-F6282-00	CAP, GRIP UNDER	1				
14	91317-05035	BOLT,HEX.SOCKET HEAD	2				
15	2CB-F6280-20	REAR VIEW MIRROR ASSY (LEFT)	1				
16	2CB-F6290-20	REAR VIEW MIRROR ASSY (RIGHT)	1				



B7D1431-U300

FIG. 31 FRONT MASTER CYLINDER

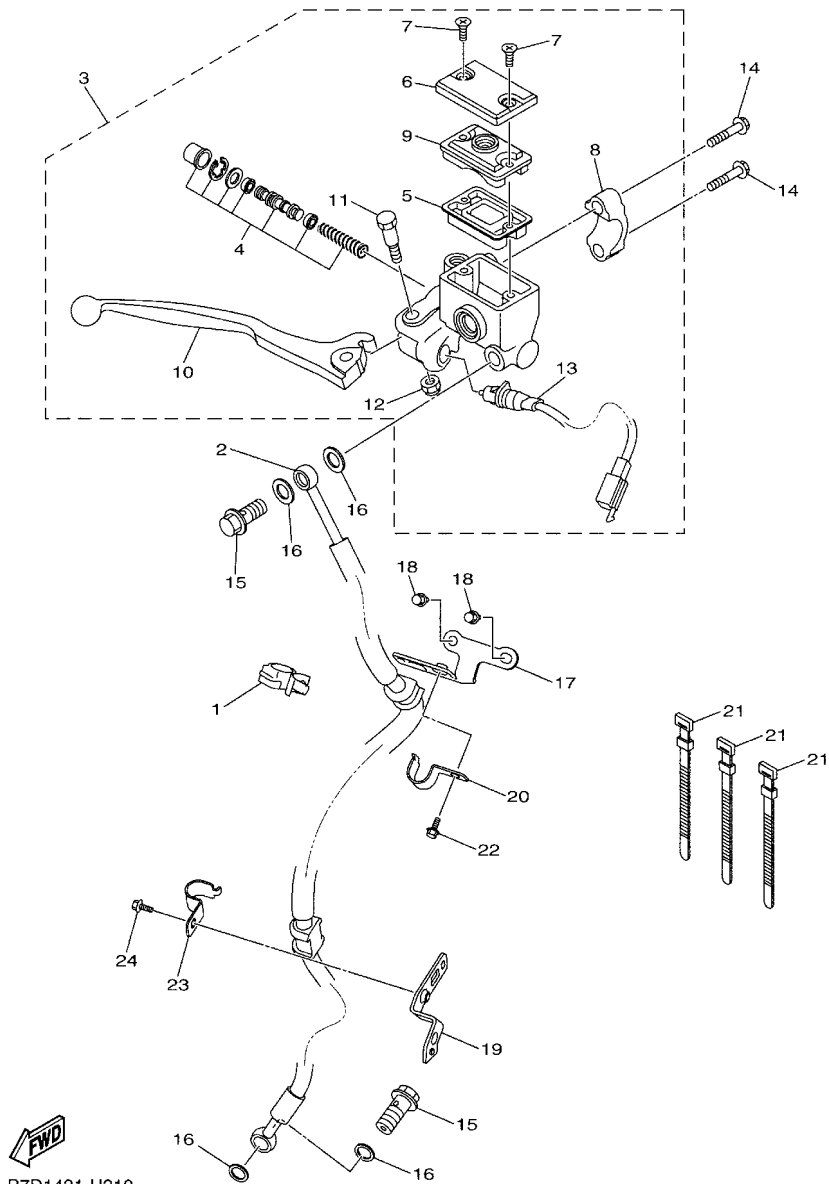

B7D1431-U310

REF. NO.	PART NO.	DESCRIPTION	BHM2				REMARKS
1	90464-18808	CLAMP	1				
2	B8D-F5872-00	HOSE, BRAKE 1	1				
3	B7D-F583T-01	MASTER CYLINDER ASSY	1				
4	5P0-F580A-00	.CYLINDER KIT, MASTER	1				
5	3RW-F5854-00	.DIAPHRAGM, RESERVOIR	1				
6	3C1-F5852-00	.CAP, RESERVOIR	1				
7	36Y-2589H-00	.SCREW	2				
8	3RW-F5867-00	.BRACKET, MASTER CYLINDER	1				
9	3C1-F5855-00	.BUSH,DIAPHRAGM	1				
10	38B-H3922-00	.LEVER 2	1				
11	90109-06577	.BOLT	1				
12	95602-06100	.NUT, SELF-LOCKING	1				
13	1YD-H3980-10	.FRONT STOP SWITCH ASSY	1				
14	95027-06025	BOLT, FLANGE	2				
15	90401-10812	BOLT, UNION	2				
16	90201-10118	WASHER, PLATE	4				
17	B8D-F5887-00	HOLDER, BRAKE HOSE 3	1				
18	95027-06010	BOLT, FLANGE	2				
19	B8D-F5876-00	HOLDER, BRAKE HOSE 2	1				
20	BG7-F5875-00	HOLDER, BRAKE HOSE 1	1				
21	3RS-H3936-00	BAND, SWITCH CORD	3				
22	95027-06010	BOLT, FLANGE	1				
23	BG7-F5875-00	HOLDER, BRAKE HOSE 1	1				
24	95027-06010	BOLT, FLANGE	1				

FIG. 32 STAND & FOOTREST

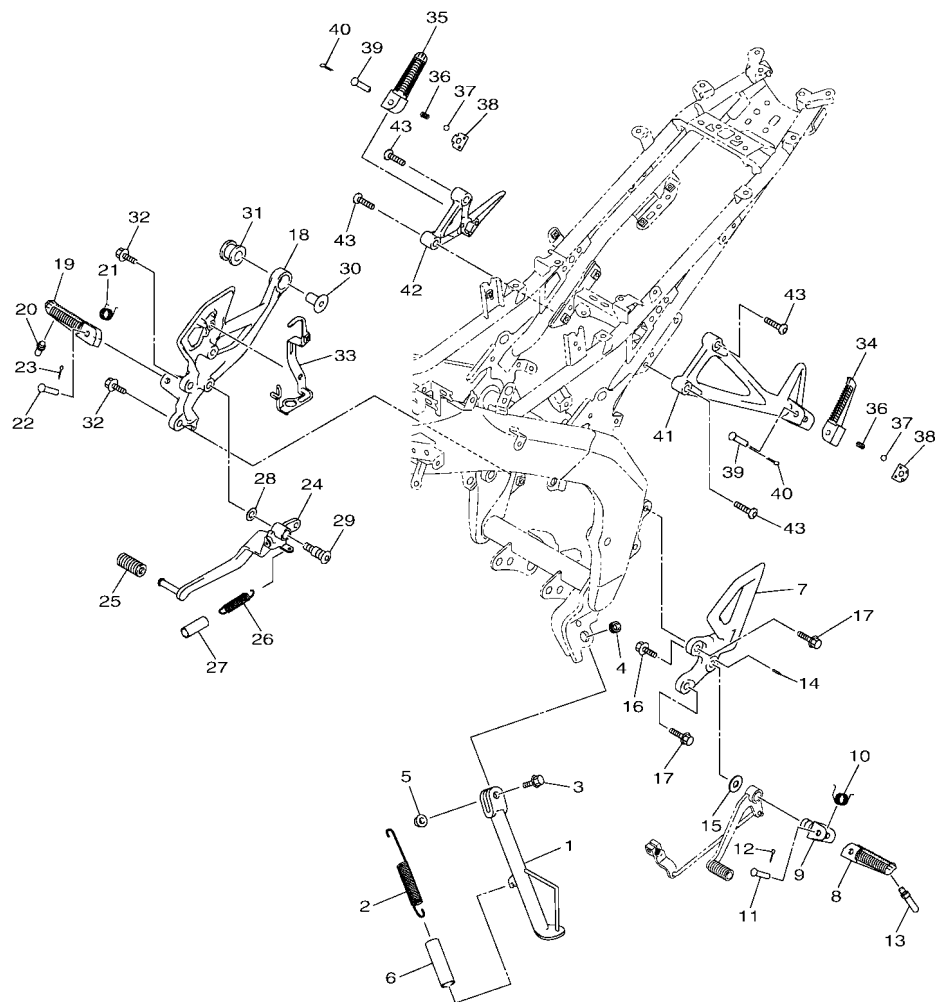

REF. NO.	PART NO.	DESCRIPTION	BHM2	REMARKS
1	B8D-F7311-00	STAND, SIDE	1	
2	90506-28800	SPRING, TENSION	1	
3	90105-10888	BOLT, FLANGE	1	
4	90387-10003	COLLAR	1	
5	95602-10200	NUT, S/L FLANGE	1	
6	90445-21848	HOSE (L70)	1	
7	B7D-F7442-00	BRACKET 2	1	
8	20P-F7451-00	FOOTREST	1	
9	2PK-F7411-00	FOOTREST 1	1	
10	90508-183B9	SPRING, TORSION	1	
11	90240-08144	PIN, CLEVIS	1	
12	91401-25015	PIN, COTTER	1	
13	2C0-27435-00	BOLT	1	UR Either can use
	20P-F7435-00	BOLT	1	UR Either can use
14	90249-02002	PIN	1	
15	90201-10066	WASHER, PLATE	1	
16	90110-10012	BOLT, HEXAGON SOCKET HEAD	1	
17	90110-08803	BOLT, HEXAGON SOCKET HEAD	2	
18	B7D-F7443-00	BRACKET 3	1	
19	20P-F7461-00	FOOTREST	1	
20	20P-F7435-00	BOLT	1	
21	90508-184B0	SPRING, TORSION	1	
22	90240-08145	PIN, CLEVIS	1	
23	91401-25015	PIN, COTTER	1	
24	B9D-F7211-00	PEDAL, BRAKE	1	
25	1EG-E8113-10	COVER, SHIFT PEDAL	1	
26	90506-20193	SPRING, TENSION	1	



B7D1431-U320

FIG. 32 STAND & FOOTREST

REF. NO.	PART NO.	DESCRIPTION	BHM2				REMARKS
27	90445-16807	HOSE	1				
28	90201-10021	WASHER, PLATE	1				
29	BS8-F7261-00	SHAFT	1				
30	90387-08842	COLLAR	1				
31	BK7-E4747-00	DAMPER, MUFFLER	1				
32	90110-08803	BOLT, HEXAGON SOCKET HEAD	2				
33	B7D-F144G-10	STAY, STOP SWITCH	1				
34	1WD-F7431-01	FOOTREST, REAR 1	1				
35	1WD-F7441-01	FOOTREST, REAR 2	1				
36	90501-12743	SPRING, COMPRESSION	2				
37	93501-04830	BALL	2				
38	B7D-F7437-00	WASHER, SPECIAL	2				
39	90240-08145	PIN, CLEVIS	2				
40	91401-25015	PIN, COTTER	2				
41	B7D-F741L-00	BRACKET 4	1				
42	B7D-F742L-00	BRACKET 5	1				
43	90110-08071	BOLT, HEXAGON SOCKET HEAD	4				

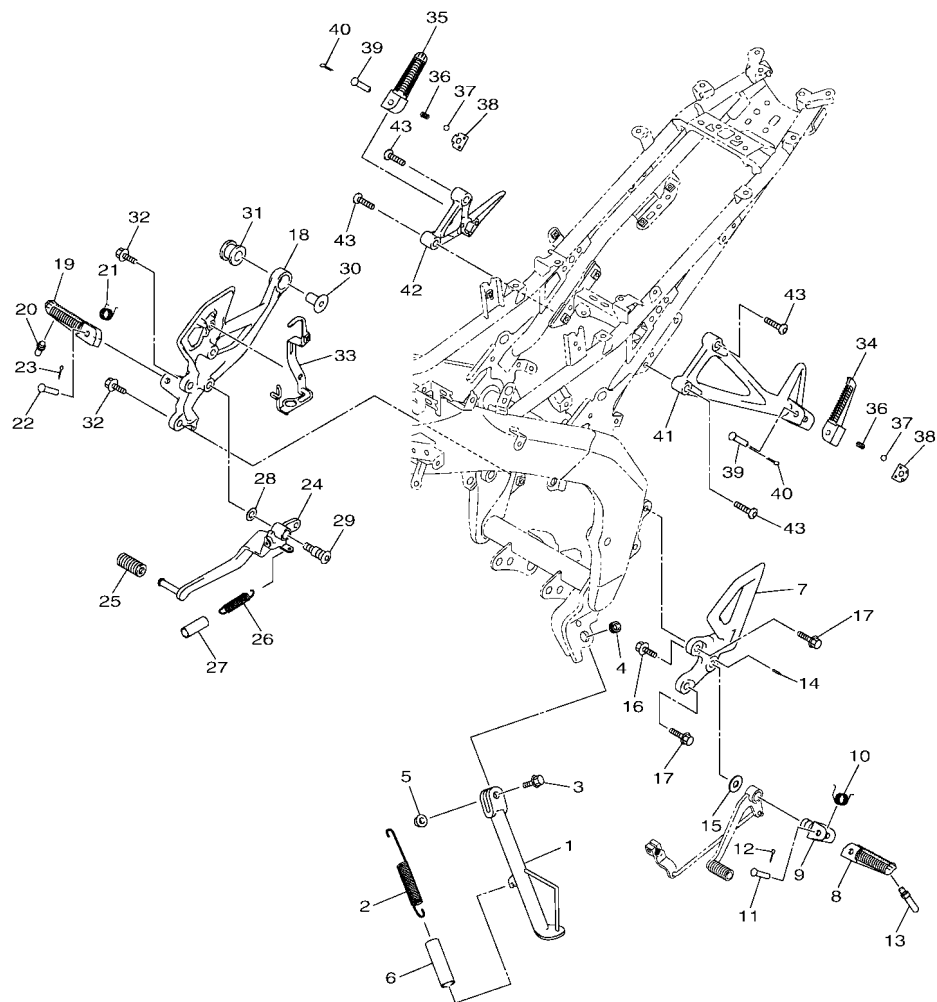

B7D1431-U320

FIG. 33 REAR MASTER CYLINDER

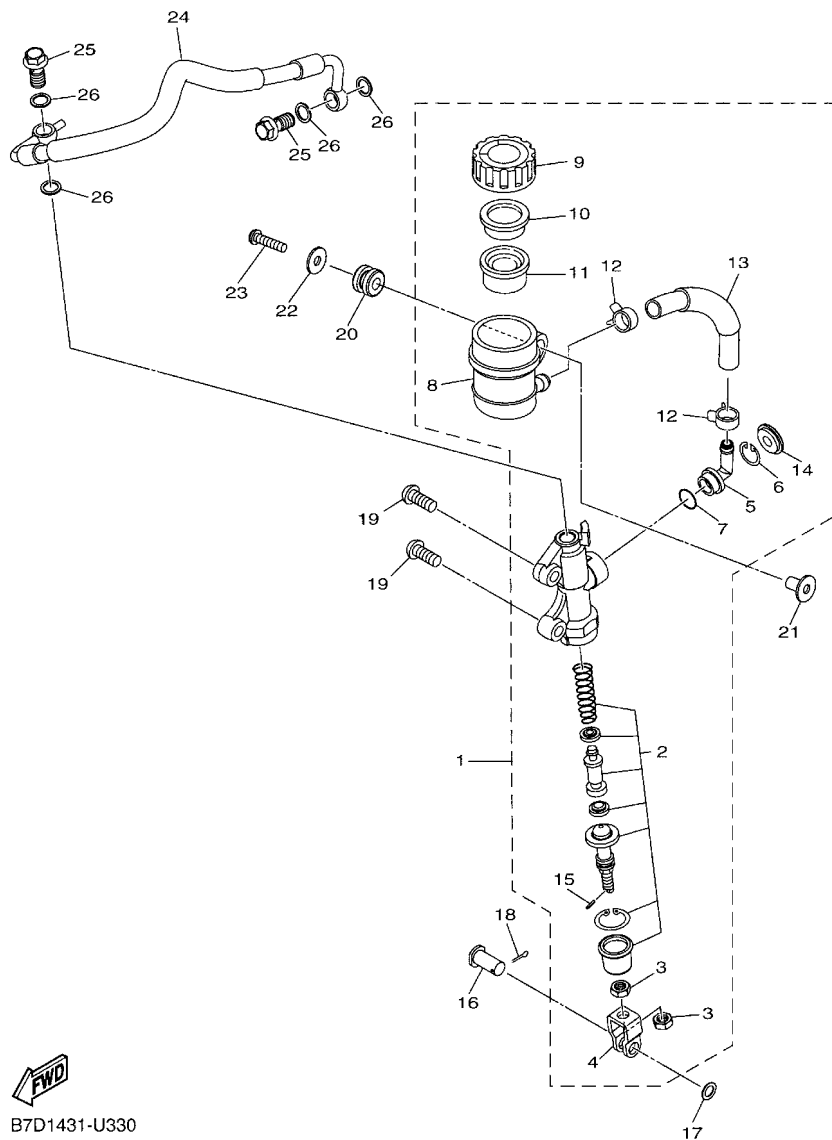



B7D1431-U330

REF. NO.	PART NO.	DESCRIPTION	BHM2				REMARKS
1	B7D-F580E-00	REAR MASTER CYLINDER ASSY	1				
2	B97-F5808-00	.CYLINDER KIT, MASTER	1				
3	95302-08700	.NUT, HEXAGON	2				
4	50C-F7222-00	.JOINT	1				
5	50C-F582A-50	.JOINT	1				
6	50C-F5866-00	.CIRCLIP	1				
7	93210-15620	.O-RING	1				
8	50C-F5894-11	.TANK, RESERVOIR	1				
9	BK6-F5852-00	.CAP, RESERVOIR	1				
10	50C-F5855-00	.BUSH, DIAPHRAGM	1				
11	2VN-F5854-00	.DIAPHRAGM, RESERVOIR	1				
12	90467-12085	.CLIP	2				
13	B7D-F5895-00	.HOSE, RESERVOIR	1				
14	50C-F589A-00	.COVER, DUST	1				
15	5BU-27234-00	.PIN, BRAKE ROD	1				
16	90240-08005	PIN, CLEVIS	1				
17	90201-08066	WASHER, PLATE	1				
18	91401-20012	PIN, COTTER	1				
19	92017-08025	BOLT, BUTTON HEAD	2				
20	50C-F4742-00	GROMMET	1				
21	50C-F6259-00	COLLAR	1				
22	90201-06828	WASHER, PLATE	1				
23	98507-06025	SCREW, PAN HEAD	1				
24	B8D-F5873-00	HOSE, BRAKE 2	1				
25	90401-10812	BOLT, UNION	2				
26	90201-10118	WASHER, PLATE	4				

FIG. 34 LEG SHIELD

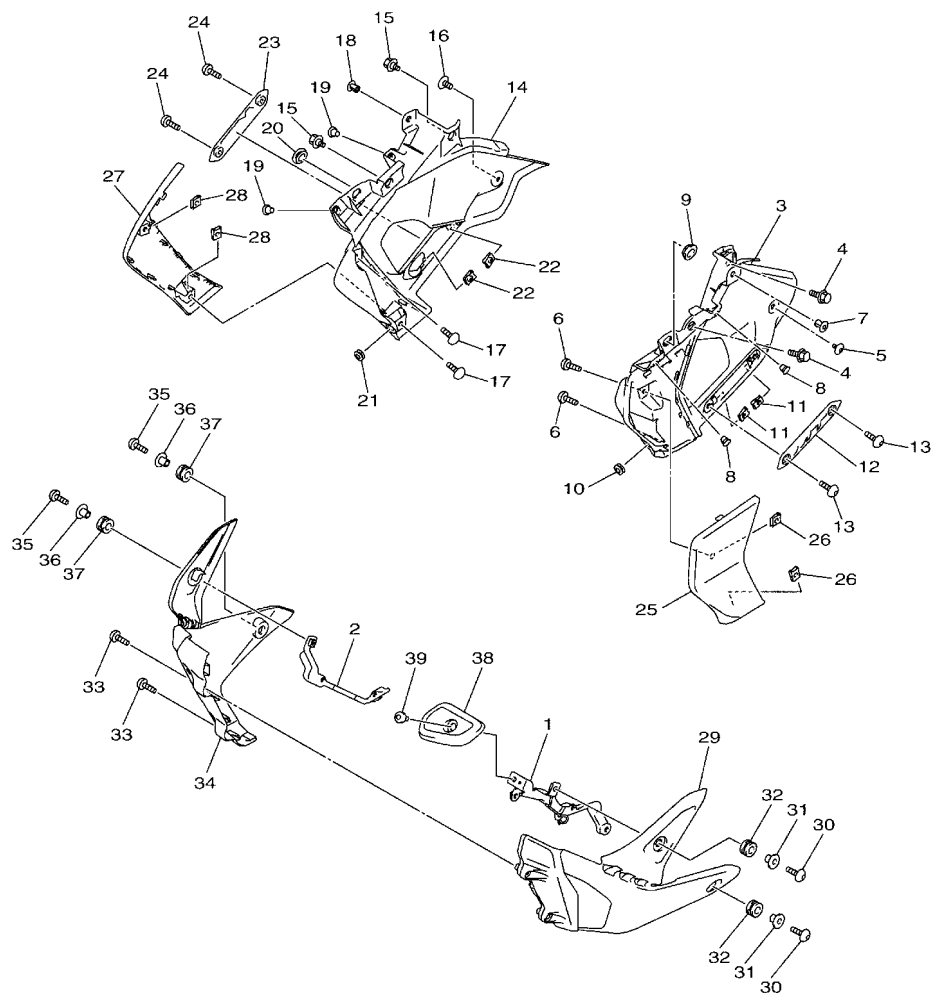
REF. NO.	PART NO.	DESCRIPTION	BHM2	REMARKS
1	B7D-F8283-00	BRACKET, POUCH	1	
2	B7D-F8284-00	BRACKET, UNDER	1	
3	B7D-F137U-00	GUIDE, AIR 1	1	
4	90109-06202	BOLT	2	
5	90110-06102	BOLT, HEXAGON SOCKET HEAD	1	
6	97707-50012	SCREW, TRUSS HEAD TAPPING	2	
7	90269-06816	RIVET	1	
8	90338-06018	PLUG	2	
9	90480-01559	GROMMET	1	
10	90480-10623	GROMMET	1	
11	90183-05807	NUT, SPRING	2	
12	B7D-F8336-00	PLATE	1	
13	90160-05810	SCREW, ROUND TAPPING	2	
14	B7D-F137V-00	GUIDE, AIR 2	1	
15	90109-06202	BOLT	2	
16	90110-06102	BOLT, HEXAGON SOCKET HEAD	1	
17	97707-50012	SCREW, TRUSS HEAD TAPPING	2	
18	90269-06816	RIVET	1	
19	90338-06018	PLUG	2	
20	90480-01559	GROMMET	1	
21	90480-10623	GROMMET	1	
22	90183-05807	NUT, SPRING	2	
23	B7D-F8336-00	PLATE	1	
24	90160-05810	SCREW, ROUND TAPPING	2	
25	B8D-F835U-00-P5	PANEL 1	1	UR FOR DPBMC,PGD
	B8D-F835U-00-P4	PANEL 1	1	UR FOR MDNM8
26	90183-05807	NUT, SPRING	2	



B7D1431-U340

FIG. 34 LEG SHIELD

REF. NO.	PART NO.	DESCRIPTION	BHM2	REMARKS
27	B8D-F835V-00-P5	PANEL 2	1	UR FOR DPBMC,PGD
	B8D-F835V-00-P4	PANEL 2	1	UR FOR MDNM8
28	90183-05807	NUT, SPRING	2	
29	B7D-F8385-00	COVER, UNDER	1	
30	90111-06117	BOLT,HEX. SOCKET BUTTON	2	
31	90387-06899	COLLAR	2	
32	90480-12808	GROMMET	2	
33	97707-50016	SCREW, TRUSS HEAD TAPPING	2	
34	B7D-F8395-00	COVER, UNDER 2	1	
35	90111-06117	BOLT,HEX. SOCKET BUTTON	2	
36	90387-06899	COLLAR	2	
37	90480-12808	GROMMET	2	
38	B9D-F8365-00	COVER	1	
39	90109-068B3	BOLT	1	

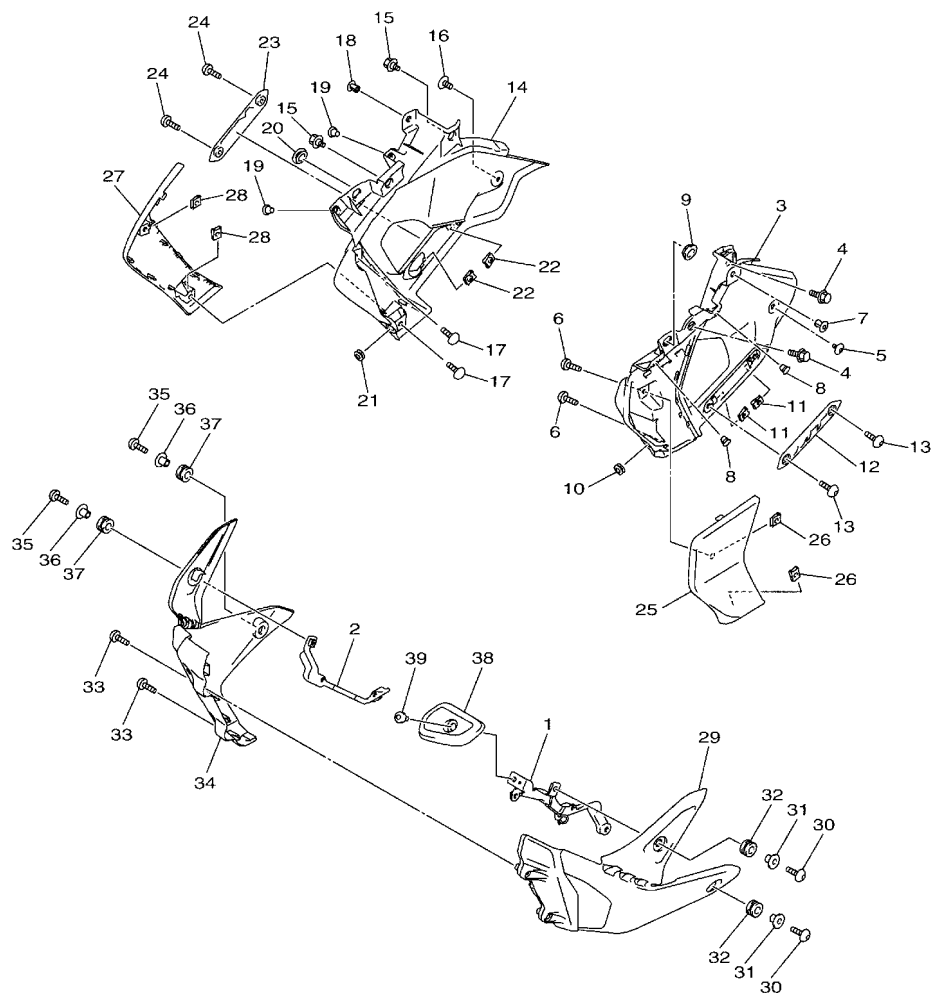

B7D1431-U340

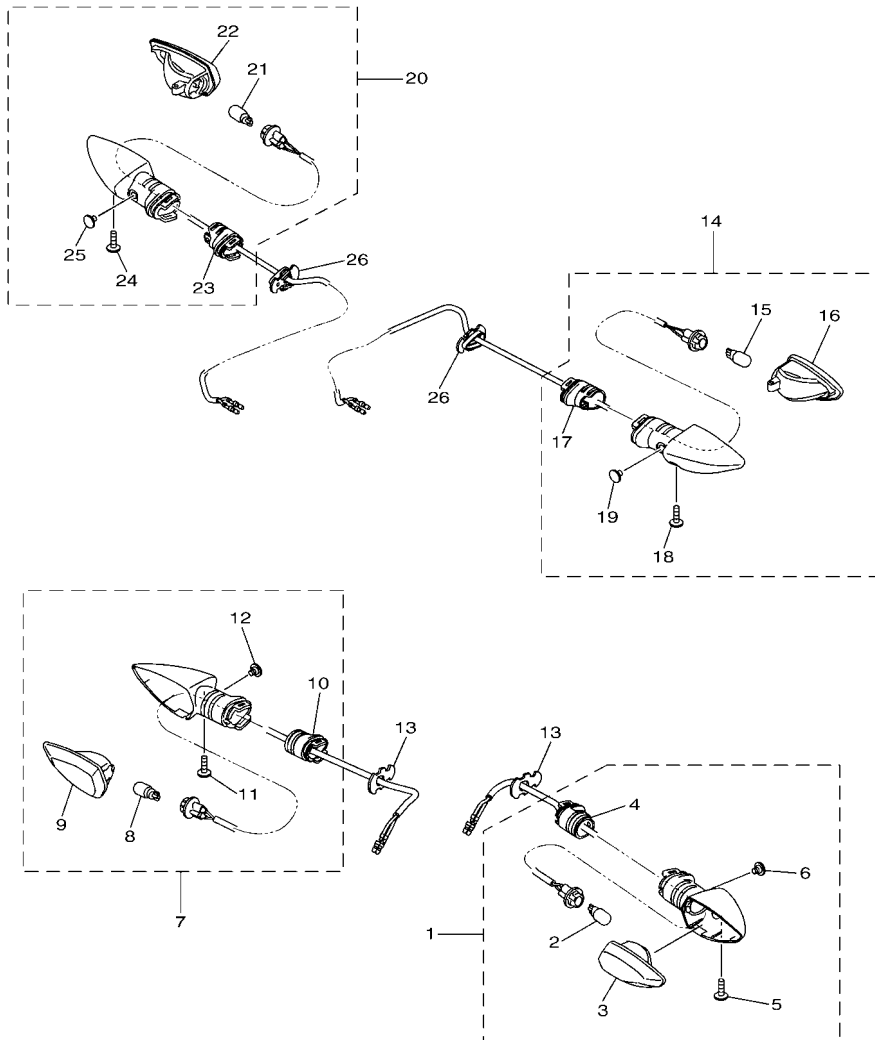

BFL1200-V370

FIG. 37 FLASHER LIGHT

REF. NO.	PART NO.	DESCRIPTION	BHM2				REMARKS
1	B48-H3310-00	FRONT FLASHER LIGHT ASSY 1	1				
2	2CB-H3311-00	.BULB, FLASHER (12V-10W)	1				
3	2CB-H333A-00	.LENS COMP 1	1				
4	1PA-H3328-00	.STAY, FLASHER 2	1				
5	1PA-H3333-00	.SCREW, LENS FITTING	1				
6	1PA-H3358-00	.SCREW, SPECIAL	1				
7	B48-H3320-00	FRONT FLASHER LIGHT ASSY 2	1				
8	2CB-H3311-00	.BULB, FLASHER (12V-10W)	1				
9	2CB-H334A-00	.LENS COMP 2	1				
10	1PA-H3328-00	.STAY, FLASHER 2	1				
11	1PA-H3333-00	.SCREW, LENS FITTING	1				
12	1PA-H3358-00	.SCREW, SPECIAL	1				
13	2PV-H3318-00	STAY, FLASHER 1	2				
14	B7D-H3330-00	REAR FLASHER LIGHT ASSY 1	1				
15	2CB-H3311-00	.BULB, FLASHER (12V-10W)	1				
16	2CB-H334A-00	.LENS COMP 2	1				
17	1PA-H3328-00	.STAY, FLASHER 2	1				
18	1PA-H3333-00	.SCREW, LENS FITTING	1				
19	1PA-H3358-00	.SCREW, SPECIAL	1				
20	B7D-H3340-00	REAR FLASHER LIGHT ASSY 2	1				
21	2CB-H3311-00	.BULB, FLASHER (12V-10W)	1				
22	2CB-H333A-00	.LENS COMP 1	1				
23	1PA-H3328-00	.STAY, FLASHER 2	1				
24	1PA-H3333-00	.SCREW, LENS FITTING	1				
25	1PA-H3358-00	.SCREW, SPECIAL	1				
26	3C1-H3318-00	STAY, FLASHER 1	2				

FIG. 38 METER

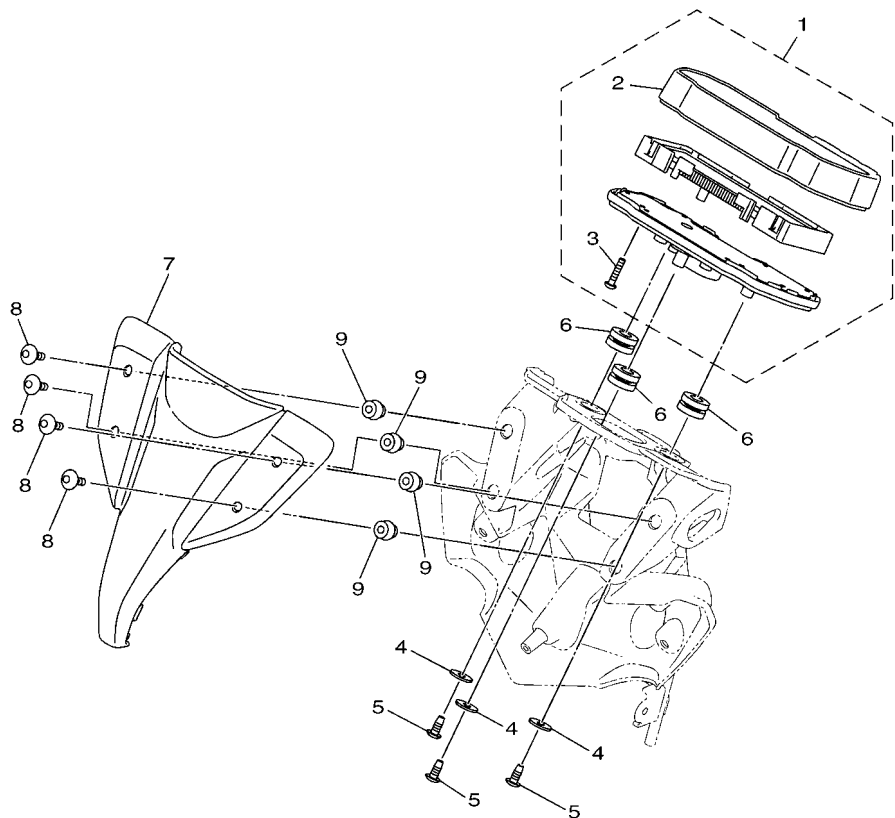

REF. NO.	PART NO.	DESCRIPTION	BHM2	REMARKS
1	B8D-H3500-03	METER ASSY	1	
2	B7D-H3571-01	.CASE, SPEEDOMETER UPPER	1	
3	97702-30016	.SCREW,TAPPING	9	
4	90201-05036	WASHER, PLATE	3	
5	97707-50014	SCREW, TRUSS HEAD TAPPING	3	
6	90480-14004	GROMMET	3	
7	B7D-F61AA-00	VISOR	1	
8	90111-05809	BOLT,HEX. SOCKET BUTTON	4	
9	90179-05849	NUT	4	

BFL1200-V380

FIG. 39 HEADLIGHT

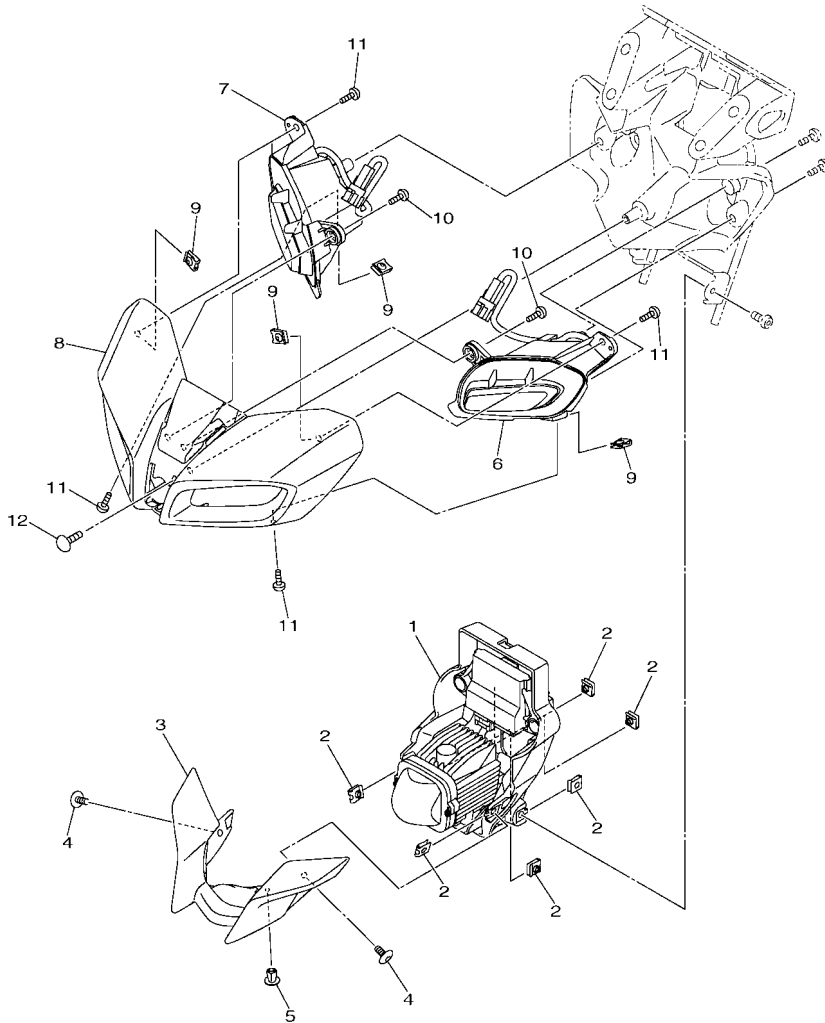

B7D1431-U390

REF. NO.	PART NO.	DESCRIPTION	BHM2	REMARKS
1	B7D-H4300-01	HEADLIGHT ASSY	1	
2	90183-050A7	NUT, SPRING	6	
3	B7D-F3122-00	COVER, OUTER 1	1	
4	90111-05003	BOLT,HEX. SOCKET BUTTON	2	
5	90269-06816	RIVET	1	
6	B7D-H4301-00	PILOT LIGHT ASSY 1	1	
7	B7D-H4302-00	PILOT LIGHT ASSY 2	1	
8	B8D-H4144-00-P1	COVER, HEADLIGHT	1	UR FOR DPBMC
	B8D-H4144-00-3E	COVER, HEADLIGHT	1	UR FOR PGD
	B8D-H4144-00-P2	COVER, HEADLIGHT	1	UR FOR MDNM8
9	90183-05807	NUT, SPRING	4	
10	97707-50012	SCREW, TRUSS HEAD TAPPING	2	
11	97707-50012	SCREW, TRUSS HEAD TAPPING	4	
12	97702-50016	SCREW,TAPPING	1	

FIG. 40 TAILLIGHT

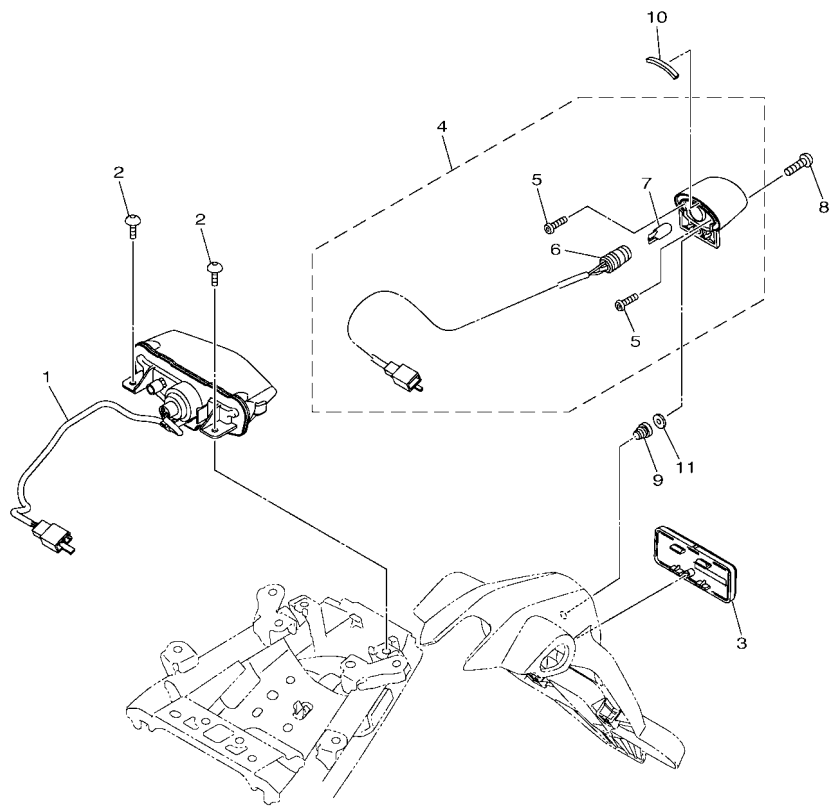

REF. NO.	PART NO.	DESCRIPTION	BHM2				REMARKS
1	B7D-H4710-00	TAILLIGHT UNIT ASSY	1				
2	97702-50016	SCREW,TAPPING	2				
3	BE1-H5130-00	REAR REFLECTOR ASSY	1				
4	BHM-H4740-00	LICENCE LIGHT ASSY	1				
5	1CK-H4726-00	.SCREW	2				
6	1WD-H4547-00	.CORD, LICENCE LIGHT	1				
7	1WD-H4744-00	.BULB (12V-5W)	1				
8	98907-04020	SCREW, BIND	1				
9	90179-04003	NUT	1				
10	90520-08820	DAMPER, PLATE	1				
11	90201-04817	WASHER, PLATE	1				



BHM2440-W400

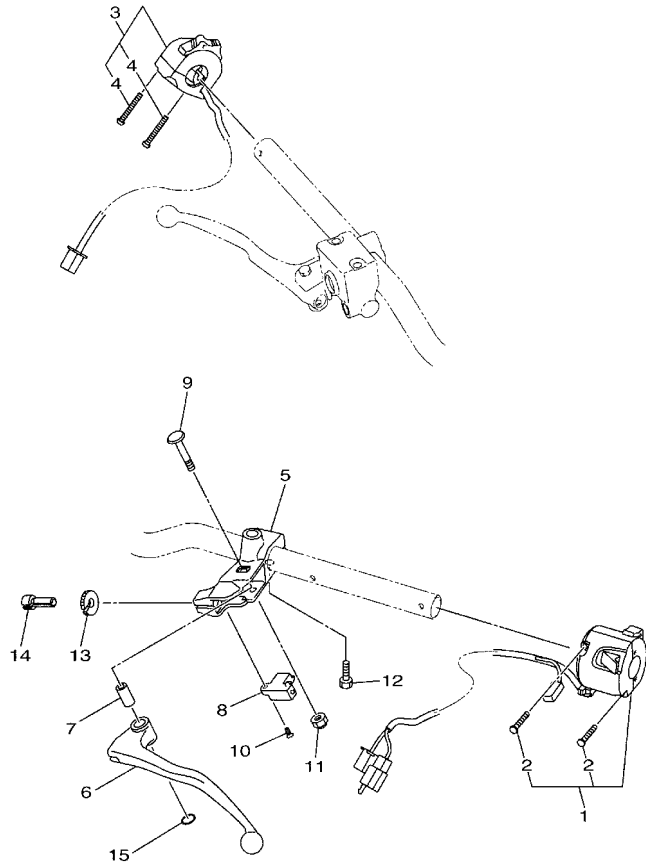
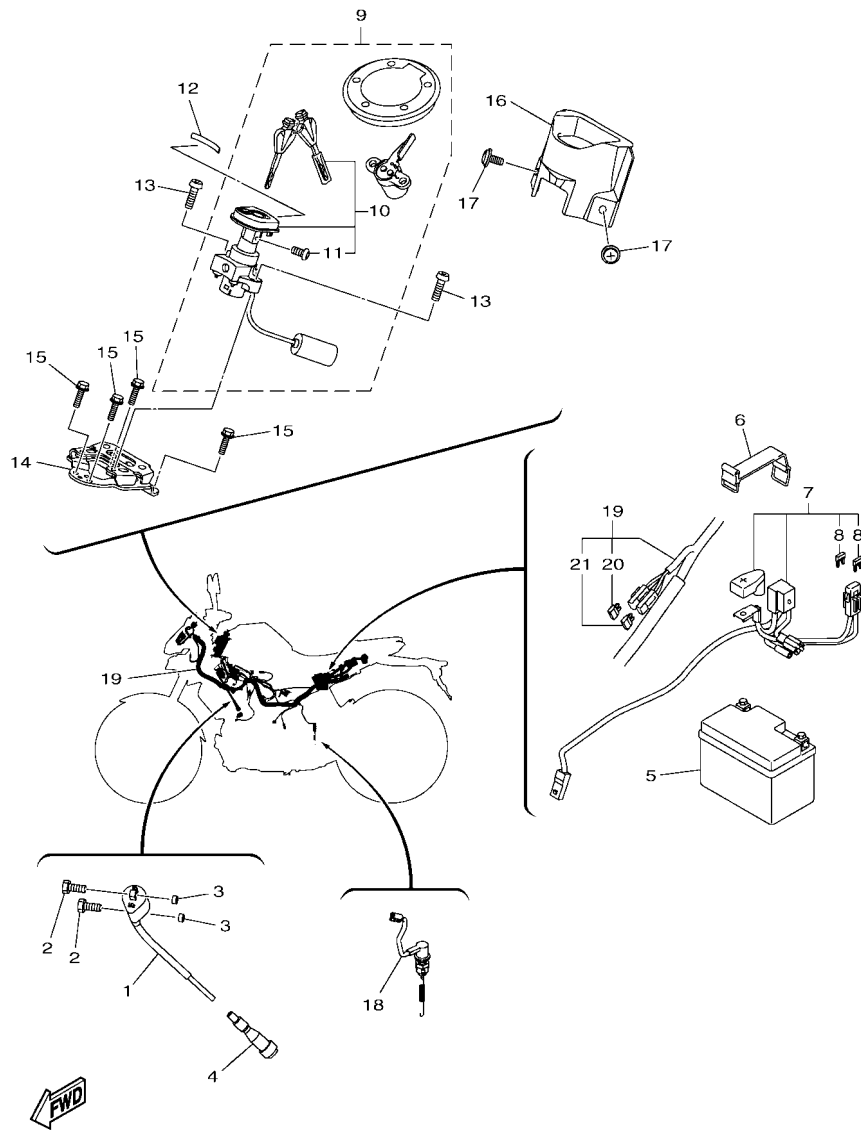

FIG. 41 HANDLE SWITCH & LEVER

REF. NO.	PART NO.	DESCRIPTION	BHM2				REMARKS
1	B8D-H3972-00	SWITCH, HANDLE 4	1				
2	98507-04025	.SCREW, PAN HEAD	2				
3	B8D-H3976-00	SWITCH, HANDLE 1	1				
4	98507-04025	.SCREW, PAN HEAD	2				
5	3KA-H2911-00	HOLDER, LEVER 1	1				
6	2TP-H3912-00	LEVER 1	1				
7	3KA-H3913-00	COLLAR, LEVER 1	1				
8	5BP-H2917-00	SWITCH	1				
9	3KA-H3945-00	BOLT, LEVER	1				
10	90151-03005	SCREW, COUNTERSUNK	1				
11	95602-06100	NUT, SELF-LOCKING	1				
12	97507-06525	BOLT, WITH WASHER	1				
13	90179-08148	NUT	1				
14	90123-08046	BOLT	1				
15	93210-108H5	O-RING	1				



B7D1431-U410



BHM2440-W420

FIG. 42 ELECTRICAL 1

REF. NO.	PART NO.	DESCRIPTION	BHM2				REMARKS
1	B0A-H2310-00	IGNITION COIL ASSY	1				
2	97080-06020	BOLT	2				
3	90387-06M30	COLLAR	2				
4	BK6-H2370-00	PLUG CAP ASSY	1				
5	14D-H2100-00	BATTERY ASSY (YUASA YTZ4V)	1				
6	B8D-H2131-00	BAND, BATTERY	1				
7	B8D-H2150-00	FUSE HOLDER ASSY	1				
8	B65-H2151-10	.FUSE (15A)	2				
9	B7D-XH250-00	MAIN SW. STRG. LOCK SUB ASSY	1				
10	B7D-H252E-00	.MAIN SWITCH COMP.	1				
11	97602-05208	..SCREW, PAN HEAD WITH WASHER	1				
12	90520-01804	DAMPER, PLATE	1				
13	90111-06177	BOLT,HEX. SOCKET BUTTON	2				
14	B8D-H252C-00	STAY, MAIN SWITCH	1				
15	90105-06090	BOLT, FLANGE	4				
16	BG7-H2568-00	COVER, MAIN SWITCH	1				
17	90159-06860	SCREW, WITH WASHER	2				
18	B2S-H2530-10	STOP SWITCH ASSY	1				
19	B8D-H2590-02	WIRE HARNESS ASSY	1				
20	B65-H2151-80	.FUSE (2A)	2				
21	B65-H2151-00	.FUSE (7.5A)	2				

FIG. 43 ELECTRICAL 2

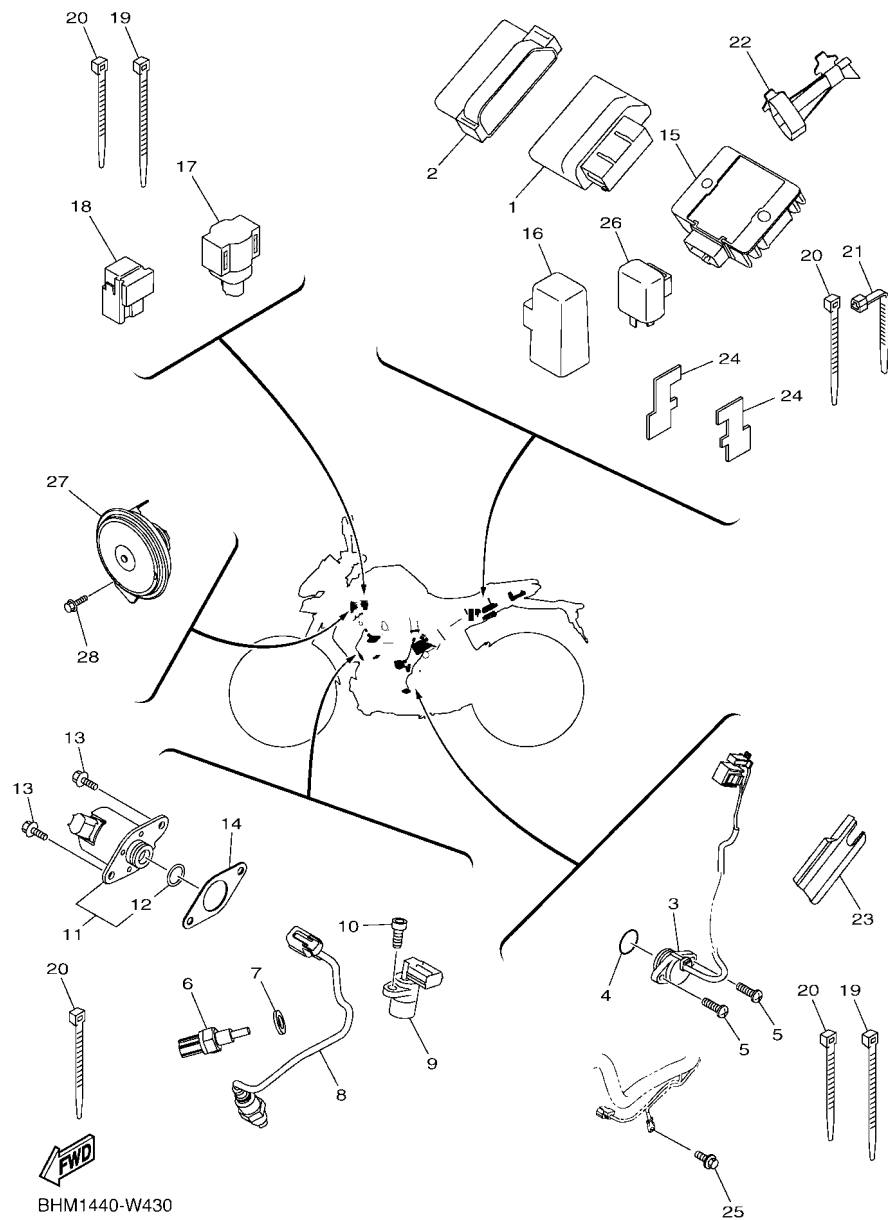

BHM1440-W430

REF. NO.	PART NO.	DESCRIPTION	BHM2	REMARKS
1	BHM-H591A-00	ENGINE CONTROL UNIT ASSY	1	
2	B8D-H5546-00	BAND	1	
3	BK6-H2540-01	NEUTRAL SWITCH ASSY	1	
4	93210-21801	O-RING	1	
5	98502-05016	SCREW,PAN HEAD	2	
6	54P-H3591-00	THERMO UNIT	1	
7	90430-10806	GASKET	1	
8	2DP-H592A-20	SENSOR, OXYGEN	1	
9	B48-H3755-01	SENSOR, SPEED	1	
10	91312-06014	BOLT, HEXAGON SOCKET HEAD	1	
11	BK6-H6110-00	SOLENOID	1	
12	BK6-H1847-00	.O-RING	1	
13	95D32-06016	BOLT, FLANGE DEEP RECESS	2	
14	BK6-H1861-00	GASKET	1	
15	BK8-H1960-00	RECTIFIER & REGULATOR ASSY	1	
16	B7D-H1940-00	STARTER RELAY ASSY	1	
17	1PA-H2576-00	SENSOR, LEAN ANGLE	1	
18	BK6-H1950-00	RELAY ASSY	1	
19	90464-50800	CLAMP	6	
20	90464-36800	CLAMP	7	
21	90464-13073	CLAMP	2	(125.0x7.0)
22	B8D-H1614-01	PROTECTOR	1	
23	B8D-H2589-00	PROTECTOR, WIRE HARNESS	1	
24	B8D-F117G-00	PROTECTOR	2	
25	95022-06012	BOLT, FLANGE	1	
26	1PA-H3350-00	FLASHER RELAY ASSY	1	
27	B7D-H3371-00	HORN	1	

NUMERICAL INDEX

PART NO.	REF. NO.	PART NO.	REF. NO.	PART NO.	REF. NO.	PART NO.	REF. NO.	PART NO.	REF. NO.	PART NO.	REF. NO.
52S-12439-00	6 - 2	BK6-E2150-00	3 - 8	BK6-E3770-00	8 - 4	BK6-E6345-00	13 - 25	B8D-F137X-00-P1	24 - 32	B48-F3111-00	22 - 30
31A-23125-31	22 - 9	21C-E2156-00	4 - 1	B7D-E3907-00	23 - 17	BK6-E6351-00	13 - 13	B8D-F137X-00-P2	24 - 32	B7D-F3117-00	22 - 14
	22 - 25	5YP-E2157-01	4 - 8	54P-E3915-00	23 - 18	BK6-E6352-00	13 - 16	BK6-F1391-00	18 - 33	B7D-F3118-00	22 - 15
5XT-25802-50	29 - 5	BK6-E2160-00	3 - 14	54P-E3938-00	8 - 8	3C1-E6356-10	13 - 19	B7D-F144G-10	32 - 33	B7D-F3120-00	22 - 20
3JD-25803-50	29 - 6	BK6-E2166-00	3 - 10	BK6-E3971-00	23 - 23	1PA-E6357-00	13 - 26	BG7-F1511-00-P4	18 - 1	B7D-F3122-00	39 - 3
5XT-25827-00	29 - 15	BK6-E2170-01	4 - 3	54P-E4137-00	8 - 9	3C1-E6358-00	13 - 18	BG7-F1511-00-P5	18 - 1	B7D-F3126-00	22 - 3
36Y-2589H-00	31 - 7	2PV-E2210-01	4 - 16	54P-E4147-00	8 - 6	BK6-E6371-00	13 - 7	B17-F1568-00	24 - 42		22 - 27
3SP-25919-51	29 - 9	BK6-E2213-00	4 - 18	5CA-E4147-00	8 - 7	BK7-E6380-00	13 - 24	B7D-F1611-00	18 - 10	4TU-F3144-00	22 - 34
3SP-25924-51	29 - 13	5MX-E2222-00	4 - 17	BK6-E4199-00	8 - 2	BK6-E6774-00	13 - 15	B7D-F1629-00	18 - 20	B48-F3144-00	22 - 5
3SP-25926-51	29 - 12	BK6-E2226-00	3 - 12	BK6-E4411-01	8 - 16	3C1-E7121-00	14 - 7	B7D-F163A-01	18 - 26		22 - 21
5BU-27234-00	33 - 15	54P-E2228-00	4 - 14	BK6-E4412-00	8 - 17	5D7-E7131-00	14 - 5	B8D-F163E-00	18 - 21	BK6-F3145-00	22 - 7
2CO-27435-00	32 - 13	B65-E2231-00	4 - 12	BK6-E441J-00	8 - 24	BK6-E7151-00	14 - 2	B8D-F1640-00	18 - 22		22 - 23
BK6-E1102-00	1 - 1	BK6-E2241-00	4 - 13	5TL-E443E-00	8 - 22	BK6-E7161-00	14 - 6	B2S-F1641-01	18 - 34	B48-F3146-00	22 - 8
B63-E111F-00	4 - 9	BK6-E2256-00	4 - 15	BK6-E4450-00	8 - 18	3C1-E7211-00	14 - 13	BK7-F1650-00	20 - 21		22 - 14
2DP-E1133-10	1 - 2	BK7-E2279-00	3 - 13	BK6-E4452-00	8 - 20	BK6-E7221-00	14 - 21	BK6-F1668-00	20 - 26	B48-F3147-00	22 - 28
BK6-E1165-00	1 - 8	BK6-E2280-01	4 - 6	BK6-E4453-00	8 - 19	BK6-E7231-00	14 - 19	B8D-F1682-00	18 - 15		22 - 31
BK7-E1166-00	8 - 27	BK6-E2288-00	4 - 7	BK7-E4613-00	9 - 5	BK6-E7241-00	14 - 18	B7D-F1711-00	19 - 1	B48-F3156-00	22 - 6
BK6-E1169-00	1 - 9	BK6-E2405-00	6 - 9	B9B-E4703-10	9 - 1	BK6-E7251-00	14 - 15	1PA-F1717-00	23 - 13		22 - 22
2DP-E1181-00	1 - 20	BK6-E2410-00	6 - 1	BK6-E4718-00	9 - 2	5D7-E7261-00	14 - 20	B7D-F171E-00	19 - 23	B48-F3158-00	22 - 12
BK7-E1185-00	5 - 4	BK7-E2422-00	5 - 1	BK7-E4747-00	32 - 31	BK6-E7411-00	14 - 1	B7D-F171X-00	19 - 27	B7D-F3170-00	22 - 11
BK6-E1191-00	1 - 7	2DP-E2428-00	5 - 3	BK6-E4799-00	9 - 3	BK6-E7421-00	14 - 12	B7D-F1721-00	19 - 6	B48-F3171-00	22 - 10
B3F-E1193-00	1 - 15	BK7-E2435-00	5 - 9	2PV-E5113-00	11 - 9	1S7-E7456-00	14 - 29	B8D-F1731-00-P5	19 - 17		22 - 26
2DP-E1311-10	1 - 24	BK7-E2443-00	5 - 12	BK6-E5150-00	10 - 1	3C1-E7471-00	14 - 10	B8D-F173E-00	19 - 31	B8D-F3174-00	21 - 24
BK6-E132G-00	1 - 13	BK7-E2450-00	5 - 5	1S7-E5351-00	7 - 3	38B-E8101-00	16 - 4	B8D-F173E-10	19 - 31	B8D-F3175-00	21 - 17
BK6-E1351-00	1 - 25	BK6-E2460-00	6 - 7	BK7-E5362-00	11 - 17	B9D-E8110-00	16 - 9	B8D-F173E-20	19 - 31	BG7-F317J-00	21 - 25
BK6-E1361-00	1 - 16	BK6-E2461-00	6 - 8	BK6-E5411-00	11 - 1	BK7-E8112-00	16 - 14	B8D-F173F-00	19 - 32	BK6-F332K-00	22 - 28
BK6-E1362-00	1 - 17	BK7-E2467-00	6 - 18	BK6-E5418-00	11 - 10	20P-E8113-00	16 - 10	B8D-F173F-10	19 - 32	B7D-F3340-00	22 - 32
BK6-E1400-00	2 - 1	BK6-E2481-00	6 - 19	BK6-E5421-00	11 - 12	1EG-E8113-10	32 - 25	B8D-F173F-20	19 - 32	4TU-F3356-00	22 - 13
BK6-E1412-00	2 - 2	BK6-E2482-00	6 - 21	BK6-E5441-00	4 - 19	B9D-E8115-00	16 - 11	B8D-F1741-00-P5	19 - 20	B7D-F3357-00	22 - 16
BK6-E1422-00	2 - 5	BK6-E2483-00	6 - 4	BK6-E5451-00	11 - 2	BK7-E8140-00	16 - 1	BK7-F1817-00	19 - 13	B7D-F3393-00	22 - 29
BK7-E1454-00	2 - 21	5P0-E2590-00	6 - 12	BK6-E5461-00	11 - 13	BK6-E8337-00	16 - 3	BK6-F1871-00	19 - 11	4FP-F3411-20	21 - 2
21C-E1496-20	2 - 16	BK7-E2615-00	5 - 8	B48-E5514-00	12 - 1	2ND-E8511-00	15 - 4	1S7-F1875-01	19 - 12	4FP-F3412-10	21 - 3
BK6-E1531-10	2 - 22	5YP-E2671-00	6 - 11	BK7-E5521-00	12 - 2	2ND-E8512-00	15 - 5	BK6-F2110-00	20 - 1	5BP-F3416-10	21 - 5
BK6-E1536-00	2 - 15	5YP-E2675-00	6 - 10	2PV-E5524-10	12 - 3	2ND-E8513-00	15 - 6	2PK-F2128-01	20 - 5	1PA-F3418-00	21 - 8
BK7-E1549-00	2 - 7	BK7-E2842-00	5 - 6	2TP-E5580-00	12 - 6	1PA-E8531-00	15 - 7	BK6-F2141-00	20 - 6	5VL-F341E-10	21 - 4
BK6-E1557-00	3 - 11	BK6-E3300-00	7 - 1	3C1-E6111-00	13 - 1	BK6-E8540-00	15 - 1	BK7-F2151-00	20 - 8	B8D-F3435-00	21 - 9
BK6-E1603-00	2 - 14	2PV-E3324-00	7 - 8	54B-E6144-00	13 - 20	5TP-E8542-00	15 - 2	1CK-F217A-00	20 - 11	B48-F3441-00	21 - 13
BK6-E1631-00	2 - 11	3C1-E3327-00	7 - 13	BK6-E6150-00	13 - 5	B8D-F1110-02	17 - 1	2PK-F217F-00	20 - 15	B48-F3442-01	21 - 14
2DP-E1633-00	2 - 12	38B-E3411-00	7 - 4	2ND-E6154-00	13 - 6	B8D-F111D-00	17 - 7	BK6-F2184-00	20 - 4	5BP-F3873-01	21 - 1
BK6-E1651-00	2 - 4	38B-E3440-01	7 - 7	38B-E6193-00	13 - 2	B8D-F117G-00	43 - 24	B7D-F2210-00	20 - 25	5BP-F3875-00	22 - 33
BK6-E1681-00	2 - 6	2PK-E3447-00	7 - 9	2ND-E6321-00	13 - 8	3C1-F1338-00	6 - 23	BK6-F2311-00	20 - 18	B8D-F4110-00	23 - 1
BK6-E2111-00	3 - 1	BK7-E3516-00	5 - 10	BK6-E6321-00	13 - 10	BK7-F135F-00	20 - 2	BK6-F2327-00	17 - 5	B8D-F411F-00	23 - 2
B63-E2113-00	3 - 4	2FB-E3556-00	8 - 10	BK6-E6324-00	13 - 12	B7D-F137U-00	34 - 3	BK6-F247A-01	19 - 14	B7D-F4121-00	24 - 20
2DP-E2117-00	3 - 6	BK6-E3557-00	8 - 11	BK6-E6325-00	13 - 11	B7D-F137V-00	34 - 14	B7D-F3100-00	22 - 1	B7D-F4122-00	24 - 23
5TL-E2118-00	3 - 5	BK6-E3585-00	8 - 1	BK6-E6331-00	13 - 9	B8D-F137W-00-3E	24 - 30	B7D-F3102-00	22 - 2	B8D-F4129-00-3E	24 - 8
54P-E2119-00	3 - 3	BK6-E3750-00	8 - 14	BK6-E6333-00	13 - 14	B8D-F137W-00-P1	24 - 30	B7D-F3103-00	22 - 19	B8D-F4129-00-P3	24 - 8
BK6-E2121-00	3 - 2	BK6-E3761-00	8 - 5	BK6-E6337-00	13 - 17	B8D-F137W-00-P2	24 - 30	B7D-F3110-00	22 - 4	B8D-F4129-00-P5	24 - 8
50C-E2126-00	3 - 7	BK6-E3767-00	8 - 13	3C1-E6344-00	13 - 21	B8D-F137X-00-3E	24 - 32	B48-F3111-00	22 - 17	B8D-F412Y-00	23 - 4

NUMERICAL INDEX

PART NO.	REF. NO.	PART NO.	REF. NO.	PART NO.	REF. NO.	PART NO.	REF. NO.	PART NO.	REF. NO.	PART NO.	REF. NO.
B8D-F4139-00-3E	24 - 14	B97-F5806-00	29 - 4	2CB-F6280-20	30 - 15	2PV-H1450-01	35 - 1	1PA-H3333-00	37 - 24	90105-10886	17 - 3
B8D-F4139-00-P3	24 - 14	B97-F5808-00	33 - 2	B7D-F6281-00	30 - 12	B8D-H1614-01	43 - 22	2CB-H333A-00	37 - 3	90105-10887	20 - 14
B8D-F4139-00-P5	24 - 14	5P0-F580A-00	31 - 4	B7D-F6282-00	30 - 13	BK6-H1800-00	36 - 1		37 - 22	90105-10888	32 - 3
2DP-F413B-00	24 - 43	B7D-F580E-00	33 - 1	2CB-F6290-20	30 - 16	2PH-H1801-10	36 - 2	B7D-H3340-00	37 - 20	90109-06202	24 - 2
	24 - 44	B48-F580U-01	27 - 3	B8D-F6301-00	30 - 9	5D9-H1828-00	36 - 5	2CB-H334A-00	37 - 9		34 - 4
54P-F414G-10	23 - 21	B97-F580W-00	29 - 3	B8D-F6335-00	30 - 10	1FD-H183G-00	36 - 3		37 - 16		34 - 15
B8D-F414J-00	23 - 26	5HH-F5824-00	29 - 10	3RS-F6372-00	30 - 11	BK6-H1847-00	43 - 12	1PA-H3350-00	43 - 26	90109-06220	18 - 12
B8D-F4188-00	23 - 14	5HH-F5825-51	29 - 14	B9D-F7211-00	32 - 24	5D9-H1861-00	36 - 4	1PA-H3358-00	37 - 6		19 - 16
B8D-F4191-00	23 - 8	50C-F582A-50	33 - 5	50C-F7222-00	33 - 4	BK6-H1861-00	43 - 14		37 - 12	90109-06279	16 - 2
B8D-F41B1-00-P1	24 - 1	1CK-F582U-00	27 - 1	BS8-F7261-00	32 - 29	B7D-H1940-00	43 - 16		37 - 19	90109-06577	31 - 11
B8D-F41B1-00-P2	24 - 1	BK6-F582W-00	29 - 1	B8D-F7311-00	32 - 1	BK6-H1950-00	43 - 18		37 - 25	90109-068B2	19 - 18
B8D-F41B1-00-P3	24 - 1	B7D-F583T-01	31 - 3	2PK-F7411-00	32 - 9	BK8-H1960-00	43 - 15	B7D-H3371-00	43 - 27		19 - 21
B04-F4254-A0	24 - 45	3C1-F5852-00	31 - 6	B7D-F741L-00	32 - 41	B7D-H1975-00	18 - 14	B8D-H3500-03	38 - 1	90109-068B3	34 - 39
B04-F4254-D0	24 - 45	BK6-F5852-00	33 - 9	B7D-F742L-00	32 - 42	14D-H2100-00	42 - 5	B7D-H3571-01	38 - 2	90109-068C3	24 - 35
B04-F4254-E0	24 - 45	2VN-F5854-00	33 - 11	1WD-F7431-01	32 - 34	5TL-H2131-00	25 - 5	54P-H3591-00	43 - 6		24 - 39
BK7-F4312-00	23 - 27	3RW-F5854-00	31 - 5	20P-F7435-00	32 - 13	B8D-H2131-00	42 - 6	B48-H3755-01	43 - 9	90110-05806	23 - 15
BK6-F4491-00	23 - 20	3C1-F5855-00	31 - 9		32 - 20	B8D-H2150-00	42 - 7	2TP-H3912-00	41 - 6	90110-06102	34 - 5
B8D-F465B-01	18 - 27	50C-F5855-00	33 - 10	B7D-F7437-00	32 - 38	B65-H2151-00	42 - 21	3KA-H3913-00	41 - 7		34 - 16
B9D-F4730-00	25 - 1	50C-F5866-00	33 - 6	1WD-F7441-01	32 - 35	B65-H2151-10	42 - 8	38B-H3922-00	31 - 10	90110-06245	23 - 9
1PM-F4741-00	25 - 2	3RW-F5867-00	31 - 8	B7D-F7442-00	32 - 7	B65-H2151-80	42 - 20	3RS-H3936-00	31 - 21	90110-06378	1 - 23
4LS-F4741-00	25 - 3	B8D-F5872-00	31 - 2	B7D-F7443-00	32 - 18	B0A-H2310-00	42 - 1	3KA-H3945-00	41 - 9	90110-06846	8 - 15
B9D-F4741-00	25 - 4	B8D-F5873-00	33 - 24	20P-F7451-00	32 - 8	BK6-H2370-00	42 - 4	B8D-H3972-00	41 - 1	90110-06873	12 - 7
50C-F4742-00	33 - 20	BG7-F5875-00	31 - 20	20P-F7461-00	32 - 19	B8D-H252C-00	42 - 14	B8D-H3976-00	41 - 3	90110-08052	23 - 3
B9D-F4780-00	25 - 6		31 - 23	B8D-F8100-00	17 - 8	B7D-H252E-00	42 - 10	1YD-H3980-10	31 - 13	90110-08071	32 - 43
B8D-F478X-00	25 - 8	B8D-F5876-00	31 - 19	55C-F815P-00	17 - 10	B2S-H2530-10	42 - 18	B8D-H4130-00	21 - 18	90110-08803	32 - 17
B8D-F479K-00	25 - 10	BK6-F587A-00	20 - 24	B7D-F8283-00	34 - 1	BK6-H2540-01	43 - 3	B8D-H4144-00-3E	39 - 8		32 - 32
1WD-F510C-01	26 - 2	B8D-F5887-00	31 - 17	B7D-F8284-00	34 - 2	BG7-H2568-00	42 - 16	B8D-H4144-00-P1	39 - 8	90110-10012	32 - 16
1WD-F5168-03-98	26 - 1	50C-F5894-11	33 - 8	B7D-F8336-00	34 - 12	1PA-H2576-00	43 - 17	B8D-H4144-00-P2	39 - 8	90111-05003	21 - 27
1WD-F5168-03-P0	26 - 1	B7D-F5895-00	33 - 13		34 - 23	B8D-H2589-00	43 - 23	B7D-H4300-01	39 - 1		39 - 4
1WD-F5168-03-P2	26 - 1	50C-F589A-00	33 - 14	B8D-F835U-00-P4	34 - 25	B8D-H2590-02	42 - 19	B7D-H4301-00	39 - 6	90111-05808	7 - 2
BG7-F5181-00	26 - 8	5HH-F5914-00	29 - 11	B8D-F835U-00-P5	34 - 25	3KA-H2911-00	41 - 5	B7D-H4302-00	39 - 7	90111-05809	38 - 8
B97-F530S-00	28 - 2	5HH-F5917-00	29 - 8	B8D-F835V-00-P4	34 - 27	5BP-H2917-00	41 - 8	1WD-H4547-00	40 - 6	90111-05817	24 - 6
B7D-F5338-00	28 - 1	5YP-F5917-00	27 - 8	B8D-F835V-00-P5	34 - 27	B48-H3310-00	37 - 1	B7D-H4710-00	40 - 1	90111-06117	34 - 30
B7D-F5338-10	28 - 1	5P0-F5919-01	27 - 10	B9D-F8365-00	34 - 38	2CB-H3311-00	37 - 2	1CK-H4726-00	40 - 5		34 - 35
B7D-F5338-30	28 - 1	5YP-F5924-00	27 - 11	B7D-F836K-00	24 - 5		37 - 8	BHM-H4740-00	40 - 4	90111-06137	18 - 4
B97-F5364-00	28 - 4	5YP-F5925-01	27 - 9	B7D-F836L-00	24 - 34		37 - 15	1WD-H4744-00	40 - 7	90111-06177	42 - 13
BK6-F5366-01	28 - 6	5HH-F5937-00	29 - 7	B7D-F836M-00	24 - 38		37 - 21	2FC-H5111-00	18 - 35	90111-06847	18 - 7
B97-F5376-00	28 - 9	5YP-F5937-00	27 - 7	B7D-F837V-00	24 - 26	2PV-H3318-00	37 - 13	BE1-H5130-00	40 - 3	90111-06856	19 - 2
B97-F5377-00	28 - 17	5YP-F5939-00	27 - 13	B7D-F837W-00	24 - 28	3C1-H3318-00	37 - 26	B8D-H5546-00	43 - 2		19 - 7
5BP-F5381-00	28 - 16	B8D-F6111-00	30 - 1	B7D-F8385-00	34 - 29	B48-H3320-00	37 - 7	B7D-H5752-00	23 - 19	90111-06860	9 - 4
B97-F5383-00	28 - 18	B7D-F61AA-00	38 - 7	B8D-F8393-40	24 - 46	1PA-H3328-00	37 - 4	BHM-H591A-00	43 - 1	90111-08087	27 - 2
1PA-F5386-00	26 - 7	1S7-F622F-00	30 - 7	B8D-F8393-50	24 - 46		37 - 10	2DP-H592A-20	43 - 8	90111-08089	29 - 2
1CK-F5388-00	28 - 21	1S7-F622H-00	30 - 6	B8D-F8393-60	24 - 46		37 - 17	BK6-H6110-00	43 - 11	90116-08846	28 - 11
BK6-F5414-00	28 - 13	1CK-F6240-01	30 - 2	B8D-F8394-40	24 - 47		37 - 23	4C9-W0048-00	27 - 6	90119-05071	18 - 25
B8D-F5452-00	28 - 10	20P-F6241-01	30 - 3	B8D-F8394-50	24 - 47	B7D-H3330-00	37 - 14	B7D-XH250-00	42 - 9	90119-06114	8 - 26
3C1-F5802-00	27 - 4	2PK-F6246-00	30 - 4	B8D-F8394-60	24 - 47	1PA-H3333-00	37 - 5	90101-08006	28 - 22	90119-06810	24 - 10
3C1-F5803-50	27 - 5	1S7-F6257-00	30 - 5	B7D-F8395-00	34 - 34		37 - 11	90105-06090	42 - 15		24 - 16
3C1-F5805-10	27 - 12	50C-F6259-00	33 - 21	BK6-H1410-02	35 - 2		37 - 18	90105-10225	17 - 2	90123-08046	41 - 14

NUMERICAL INDEX

PART NO.	REF. NO.	PART NO.	REF. NO.	PART NO.	REF. NO.	PART NO.	REF. NO.	PART NO.	REF. NO.	PART NO.	REF. NO.
90149-05801	1 - 10	90201-06029	18 - 9	90340-14824	11 - 5	90480-01803	6 - 17	92012-06016	20 - 22	93450-16115	2 - 13
90149-08220	9 - 8	90201-06557	18 - 38	90340-32823	11 - 7	90480-10623	34 - 10	92017-05016	24 - 27	93501-04830	32 - 27
90149-10804	27 - 14	90201-06828	33 - 22	90387-06205	18 - 2		34 - 21		24 - 29	93505-16844	13 - 37
90151-03005	41 - 10	90201-06880	6 - 15	90387-064W3	6 - 16	90480-12072	18 - 5	92017-08025	33 - 19	93604-08071	2 - 20
90154-05041	21 - 26	90201-08066	33 - 17	90387-06899	24 - 11	90480-12805	18 - 3	92902-06200	16 - 12	93608-30839	16 - 7
90159-06860	19 - 5	90201-08612	9 - 7		24 - 17	90480-12808	24 - 9	93101-10843	11 - 19	93822-14800	14 - 28
	19 - 10	90201-08859	1 - 18		34 - 31		24 - 15	93102-08800	1 - 14	93900-00824	26 - 6
	42 - 17	90201-10021	32 - 28		34 - 36		34 - 32	93102-12862	13 - 29		28 - 15
90160-05810	34 - 13	90201-10066	32 - 15	90387-068M3	23 - 6		34 - 37	93102-12891	16 - 8	94111-17801	26 - 5
	34 - 24	90201-10118	31 - 16		23 - 11	90480-14004	38 - 6	93102-22827	14 - 27	94114-17802	28 - 14
90170-05803	3 - 9		33 - 26	90387-068P5	18 - 6	90480-15363	6 - 13	93103-10801	5 - 2	94568-J9096	4 - 11
	3 - 15	90201-12019	13 - 3	90387-068S1	20 - 9	90480-18813	23 - 5	93106-17801	20 - 17	94568-K1131	28 - 24
90170-10012	2 - 28		35 - 6		20 - 20		23 - 10	93106-22808	28 - 5	94668-K1021	28 - 25
90170-14801	13 - 23	90201-15814	28 - 20		20 - 23	90501-06022	15 - 3	93106-26815	26 - 3	94700-00439	1 - 19
90176-22081	21 - 11	90201-15821	2 - 17		21 - 20	90501-06800	15 - 8		28 - 8	95022-06010	14 - 30
90179-04003	40 - 9	90201-173F4	14 - 24	90387-06M30	42 - 3	90501-12743	32 - 36	93210-09806	4 - 4	95022-06012	43 - 25
90179-05849	24 - 36	90201-220T0	21 - 12	90387-08079	21 - 22	90501-16800	2 - 19	93210-108H5	41 - 15	95022-06016	11 - 11
	24 - 40	90201-22793	14 - 22	90387-08842	32 - 30	90501-18576	7 - 5	93210-148F8	11 - 6		25 - 11
	38 - 9	90201-25290	12 - 5	90387-10003	32 - 4	90506-20193	32 - 26	93210-15620	33 - 7	95022-06030	23 - 7
90179-08148	41 - 13	90202-26142	21 - 7	90387-10814	20 - 13	90506-28800	32 - 2	93210-19809	5 - 14		23 - 12
90179-10805	17 - 4	90208-20003	13 - 31	90387-15810	2 - 23	90508-09007	18 - 29		11 - 18	95022-06040	10 - 6
	20 - 16	90209-17285	14 - 3	90387-17804	14 - 14	90508-183B9	32 - 10	93210-21801	43 - 4		11 - 4
90179-12808	13 - 4	90209-18208	14 - 16	90401-10812	31 - 15	90508-184B0	32 - 21	93210-26805	36 - 6		11 - 15
90179-25615	21 - 6	90214-10800	2 - 18		33 - 25	90508-32837	16 - 5	93210-32816	11 - 8	95022-06045	10 - 4
90183-03010	18 - 30	90215-10803	2 - 27	90430-06803	1 - 5	90520-01804	42 - 12	93210-34802	7 - 6	95022-06050	11 - 16
90183-050A7	18 - 24	90215-14802	13 - 22		1 - 27	90520-03800	23 - 24	93210-39803	5 - 11	95022-06055	10 - 3
	24 - 4	90240-08005	33 - 16	90430-10806	43 - 7	90520-08007	23 - 25	93210-54805	7 - 12	95022-06070	10 - 5
	39 - 2	90240-08144	32 - 11	90445-16807	32 - 27	90520-08804	18 - 32	93306-000Y3	5 - 7	95022-06090	11 - 20
90183-05807	18 - 13	90240-08145	32 - 22	90445-21848	32 - 6	90520-08820	40 - 10	93306-001YJ	4 - 5	95022-08020	21 - 23
	19 - 3		32 - 39	90450-27806	6 - 20	90560-08326	18 - 11	93306-054XC	28 - 7	95027-06010	31 - 18
	19 - 8	90241-03800	18 - 28	90450-43805	8 - 30	91312-05010	23 - 16	93306-054XF	14 - 8		31 - 22
	19 - 25	90249-02002	32 - 14	90464-13073	43 - 21		23 - 22	93306-203XK	2 - 24		31 - 24
	19 - 29	90252-18800	16 - 13	90464-18808	31 - 1	91312-05016	4 - 2		2 - 25	95027-06014	21 - 21
	24 - 3	90269-06816	18 - 18	90464-36800	43 - 20	91312-06014	43 - 10	93306-252YN	14 - 9	95027-06025	31 - 14
	24 - 7		19 - 4	90464-50800	43 - 19	91312-06016	35 - 4	93306-252YP	28 - 3	95302-08700	28 - 23
	24 - 13		19 - 9	90465-13M24	17 - 9	91312-06020	8 - 3	93306-253X2	14 - 25		33 - 3
	24 - 19		19 - 26	90467-08003	19 - 15	91312-06025	35 - 3	93306-272YC	14 - 26	95602-06100	31 - 12
	24 - 21		19 - 30	90467-11825	8 - 29	91312-10040	22 - 35	93306-302YN	26 - 4		41 - 11
	24 - 24		24 - 37	90467-12052	8 - 28	91317-05035	30 - 14	93306-305X7	2 - 8	95602-06200	18 - 31
	34 - 11		24 - 41	90467-12085	33 - 12	91317-06030	30 - 8	93306-305XV	2 - 9		18 - 39
	34 - 22		34 - 7	90467-12800	8 - 23	91317-08030	21 - 16	93310-325YC	12 - 4	95602-08200	28 - 12
	34 - 26		34 - 18	90467-19803	6 - 5	91317-08035	21 - 10	93310-526YT	2 - 3	95602-10200	32 - 5
	34 - 28		39 - 5	90467-20804	8 - 25	91401-20012	33 - 18	93315-112Y8	13 - 28	95602-12200	20 - 7
	39 - 9	90280-03017	2 - 10	90467-20805	6 - 22	91401-25015	32 - 12	93315-317Y1	20 - 12	95602-14200	26 - 9
90183-06800	18 - 19	90282-05031	2 - 26	90467-20806	6 - 6		32 - 23	93317-218Y1	20 - 3		28 - 19
90185-10815	21 - 15	90338-06018	34 - 8	90480-01558	17 - 6		32 - 40	93410-20038	14 - 4	95607-06200	18 - 16
90201-04817	40 - 11		34 - 19	90480-01559	34 - 9	92012-06016	20 - 10	93410-22039	14 - 17	95612-08618	1 - 6
90201-05036	38 - 4	90340-12813	1 - 3		34 - 20		20 - 19		14 - 23	95702-06500	18 - 8

NUMERICAL INDEX

PART NO.	REF. NO.	PART NO.	REF. NO.	PART NO.	REF. NO.	PART NO.	REF. NO.	PART NO.	REF. NO.	PART NO.	REF. NO.
95702-08500	9 - 6	98507-04025	41 - 4								
95702-12500	35 - 5	98507-06020	18 - 37								
95707-05500	18 - 36	98507-06025	33 - 23								
95707-06500	25 - 7	98512-06012	14 - 11								
95812-06030	8 - 12	98907-04020	40 - 8								
95822-06012	18 - 17	99001-10600	16 - 6								
95822-06014	25 - 9	99009-20500	13 - 30								
95D32-06012	43 - 28	99530-08012	1 - 12								
95D32-06016	43 - 13	99530-10114	1 - 21								
95D32-06025	6 - 14		1 - 22								
95E32-06010	1 - 4		10 - 2								
	1 - 26		11 - 3								
95E32-06012	7 - 14		11 - 14								
95E32-06014	4 - 10										
95E32-06020	6 - 3										
	7 - 10										
95E32-06025	4 - 20										
	5 - 13										
95E32-06030	1 - 11										
95E32-06080	7 - 11										
97012-06020	16 - 15										
97080-06020	42 - 2										
97507-06525	41 - 12										
97602-05208	42 - 11										
97702-30016	38 - 3										
97702-50012	24 - 31										
	24 - 33										
97702-50016	18 - 23										
	24 - 12										
	24 - 18										
	24 - 22										
	24 - 25										
	39 - 12										
	40 - 2										
97707-50012	21 - 19										
	34 - 6										
	34 - 17										
	39 - 10										
	39 - 11										
97707-50014	38 - 5										
97707-50016	19 - 19										
	19 - 22										
	19 - 24										
	19 - 28										
	34 - 33										
97707-50025	8 - 21										
98502-05016	43 - 5										
98507-04025	41 - 2										